

ZEPHYR

More Than Just Play

AMUSEMENT PARK

Blix

DO-IT YOURSELF MANUAL

- 1 Read all instructions carefully before constructing.
- 2 Place all the pieces used in a step on the side before starting.
- 3 Always re-check the construction after every step.

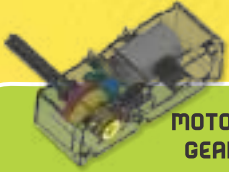

MOTORISED
GEARBOX

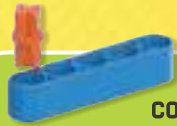

QUICK
CONSTRUCTION



GEAR
SYSTEM



2 WAY
SWITCH

AGE
7-99

MODELS
7

PIECES
340+



How to construct

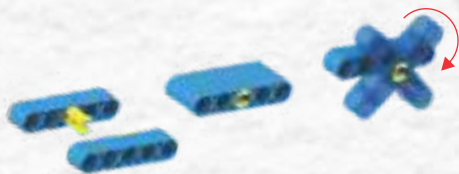

I - CL2 - Use this connector to loosely connect 2 pieces.



II - CT2 - Use this connector to attach 2 pieces.



III - CT3 - Use this connector to attach 3 pieces.

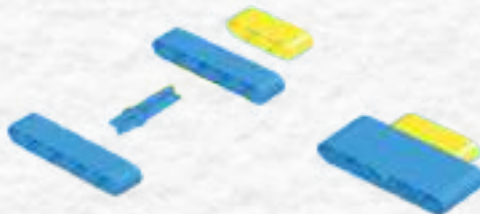

During assembly ensure position of collar is same as in the image in manual.

How to dismantle

- Narrow edge to remove connectors
- Fit the tool into narrow side of connector collar



- Broad edge to split two pieces

Important Information:

- How to remove and insert the batteries
- Non-rechargeable batteries are not to be recharged.
- Rechargeable batteries are only to be charged under adult supervision.
- Rechargeable batteries are to be removed from the toy before being charged.
- Different types of batteries or new and used batteries are not to be mixed.
- Batteries are to be inserted with the correct polarity.
- Exhausted batteries are to be removed from the toy.
- The supply terminals are not to be short-circuited

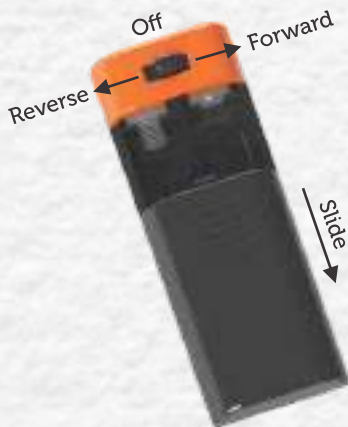

GEARS!

Reminds you of the gear stick near the driver in a car, doesn't it? Well why is that stick there? Have you noticed when it is used? Do you feel more speed when the gear goes up? And do you hear the engine growl when you don't change the gear in time? So why put such a clunky noisy device in a car!

Gears are all around us in most machines that we use daily like cars, watches, toys, printers etc. And they are a fascinating and integral part of our world today. In this set, we shall be using gears in a number of places to change speed, power, direction etc. Before we start building, let's understand a few applications of Gears!

1. To Change Speed:

You must've noticed how gears in a car helps to change the speed. When the car starts, we select 1st gear to start moving, gradually increasing gears till the top gear for highest speed.

$$\text{Calculations: } \frac{\text{Teeth on big gear}}{\text{Teeth on small gear}} = \frac{\text{Speed of small gear}}{\text{Speed of big gear}}$$

$$\text{Therefore: } \frac{60}{20} = \frac{\text{Speed of small gear}}{\text{Speed of big gear}}$$

Therefore: Speed of small gear = 3X Speed of big gear

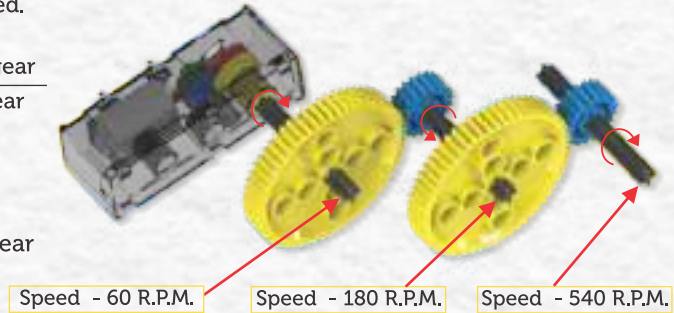

2. To change Torque (Power):

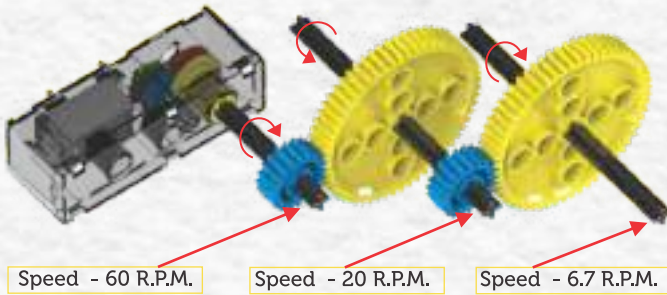

Torque is the twisting force that is required to move the car. In a car, the top gear doesn't have enough torque to rotate the wheels, hence we first have to shift over the lower gears, where torque is high.

Speed and power have a funny relationship when it comes to gears. If gears increase speed, power reduces and if gears reduce speed, power increases. And they always increase or decrease in the same ratio. If the gears are connected to reduce speed (by connecting the motor to the smaller gear), the power increases by three times.

So now we know that the 1st gear has more torque and less speed and the 5th gear has more speed and less torque.

3. Changing Direction of rotation:

There may be some applications where the direction of rotation is specified, but what if the motor runs in the opposite direction? Any 2 gears meshing together, rotate in opposite directions.

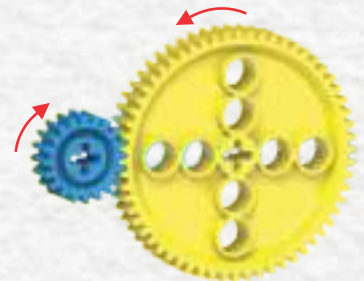

4. Changing Distance:

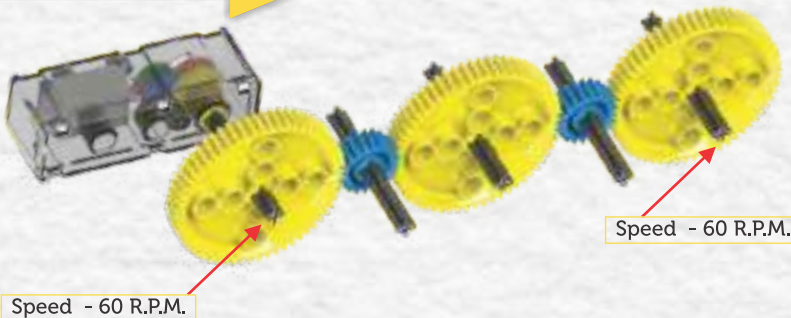

Many gears can be attached together in a straight line to increase distance between input axis and output axis. In such a case, only the size of the first and last gear affect the speed. The gears in the middle are thus called idler gears.

Model 1



Step 1

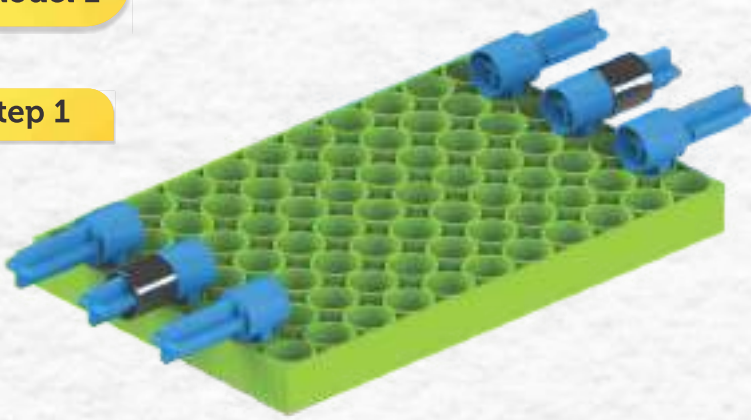

TW1 2 pcs.

CH2 6 pcs.

CT3 6 pcs.

P7X11 1 pc.

Step 2

CT2 8 pcs.

P5 2 pcs.

P11 4 pcs.

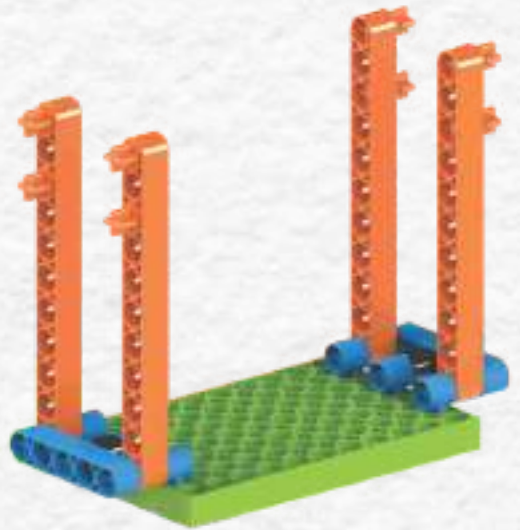

Step 3

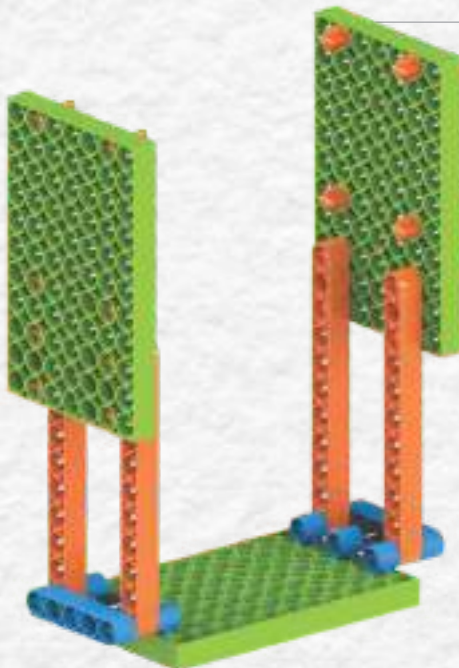

CT2 8 pcs.

P7X11 2 pcs.

Step 4

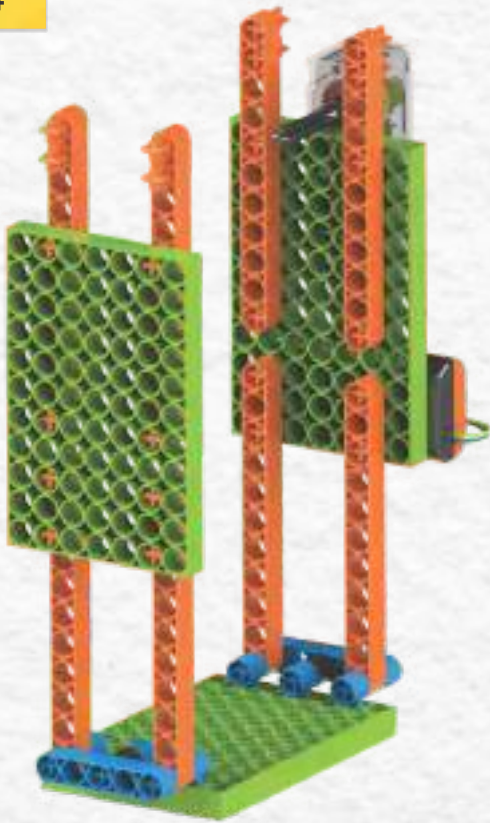

CT2 8 pcs.



Motor with
Battery Box



P11 4 pcs.

Step 5



CT2 2 pcs.



CT3 6 pcs.

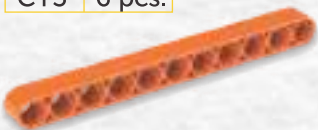

P11 4 pcs.

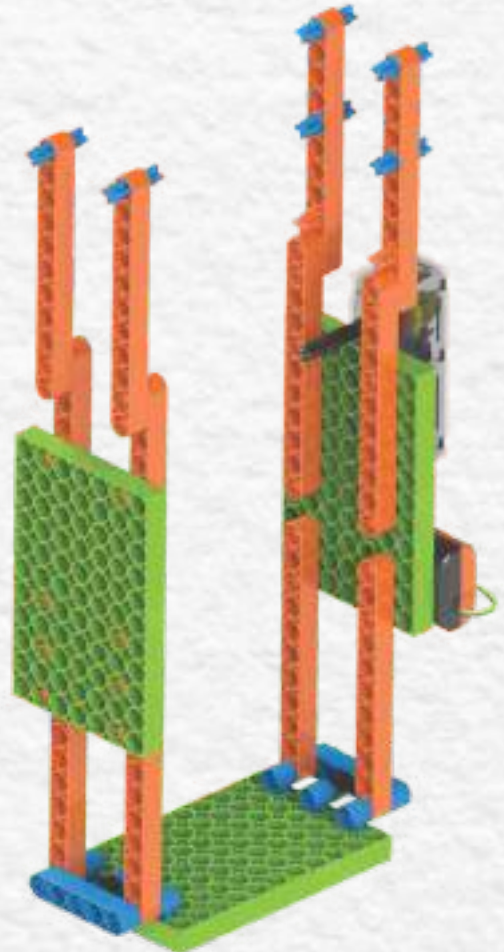

Step 6

Blix

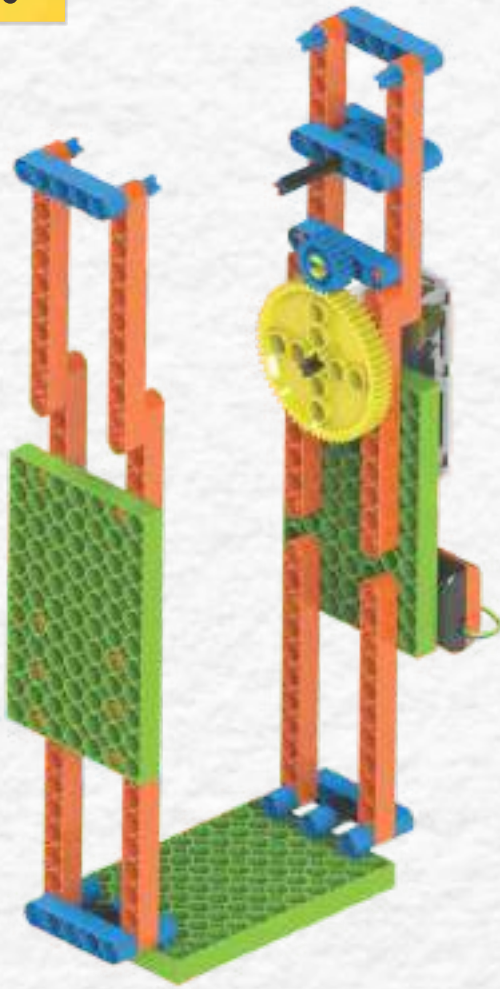

CL2 1 pc.

P5 5 pcs.

SH60 1 pc.

G(20) 1 pc.

G(20) Idler 1 pc.

G(60) 1 pc.

Step 7

G(20) 1 pc.

G(60) 1 pc.

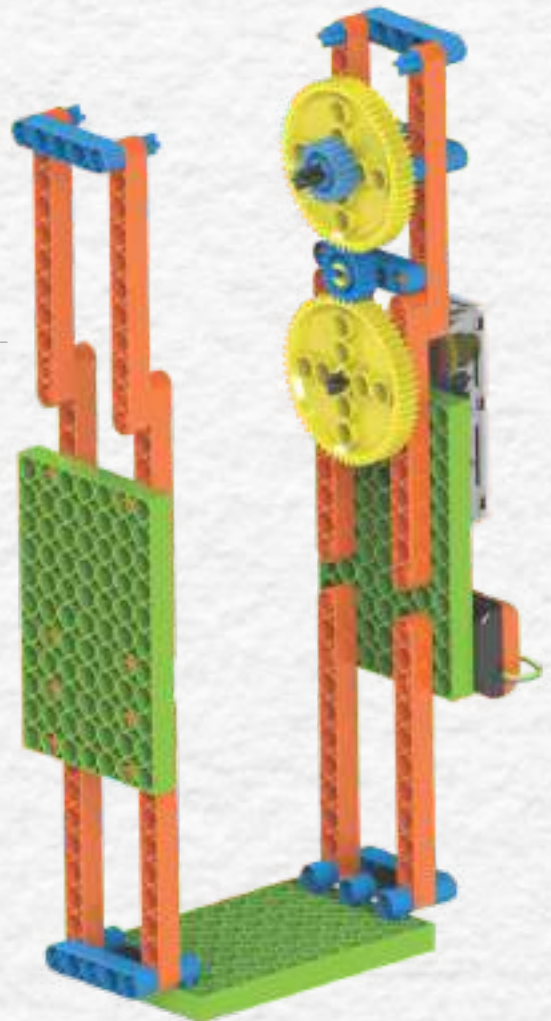

Step 8

CT2 10 pcs.

CT3 2 pcs.



P11 8 pcs.

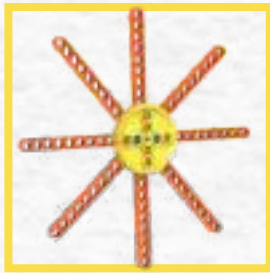

G(60) 1 pc.



Step 9

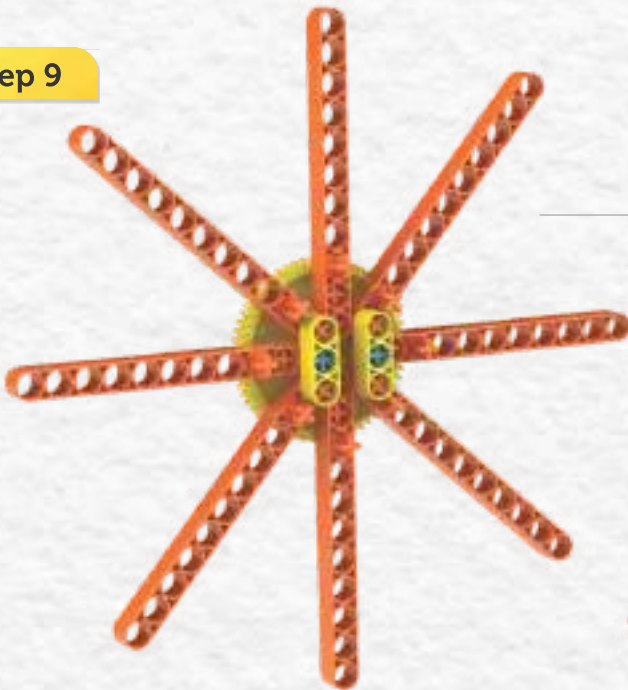

CT2 8 pcs.

P3 2 pcs.

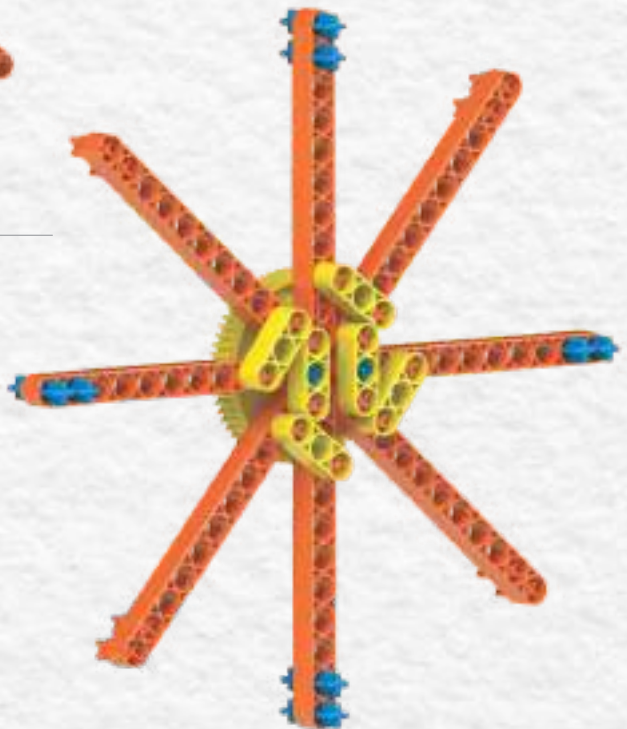

Step 10

CT2 8 pcs.

CT3 8 pcs.

P3 4 pcs.

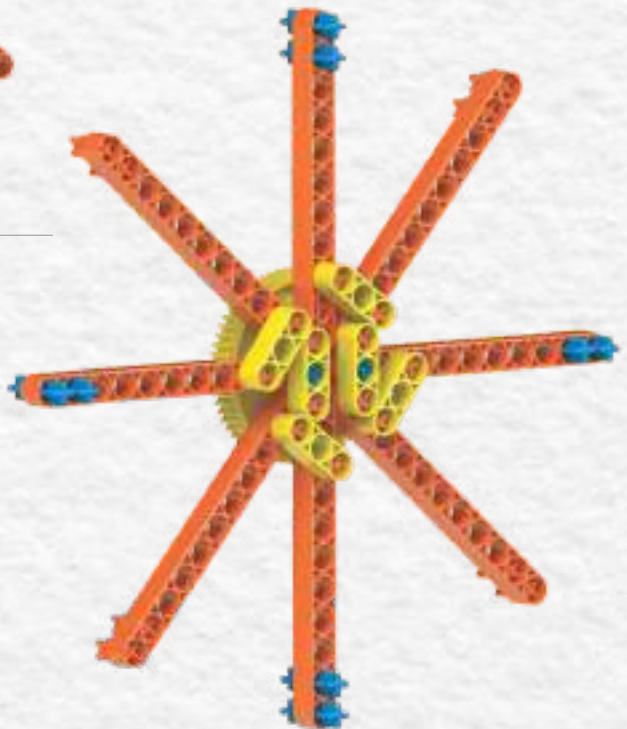

Step 11





-  CT2 8 pcs.
-  CT3 8 pcs.
-  P5 8 pcs.

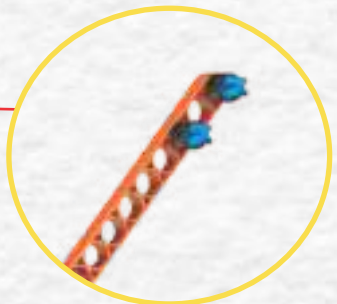
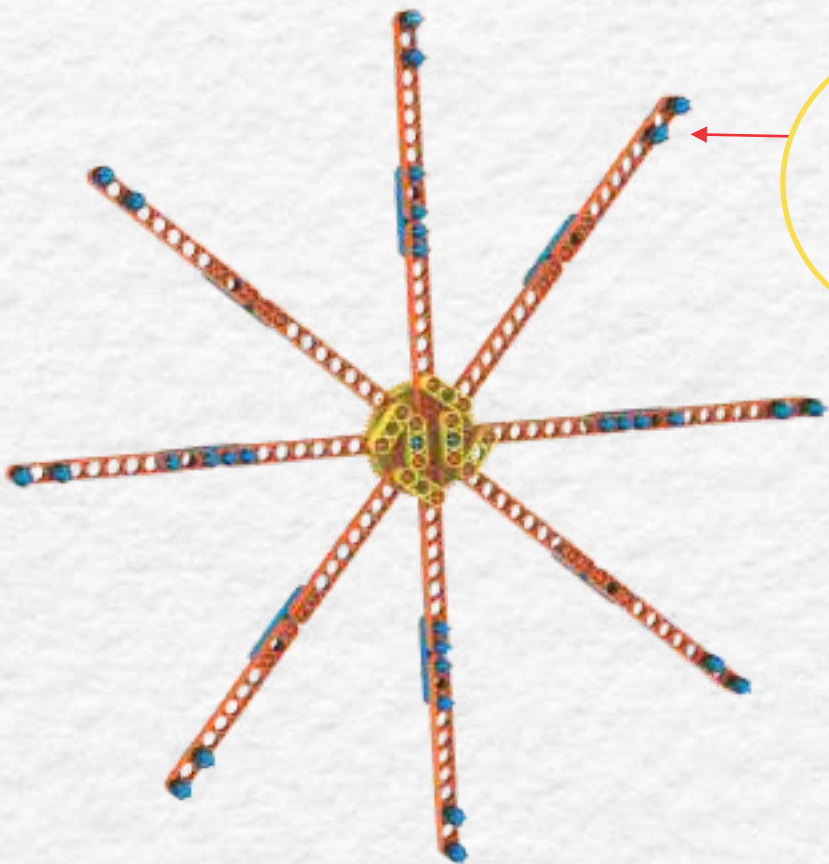

Step 12



-  CT3 16 pcs.
-  TW1 16 pcs.
-  P11 8 pcs.

Step 13



 CL2 8 pcs.

 P3 8 pcs.

Step 14

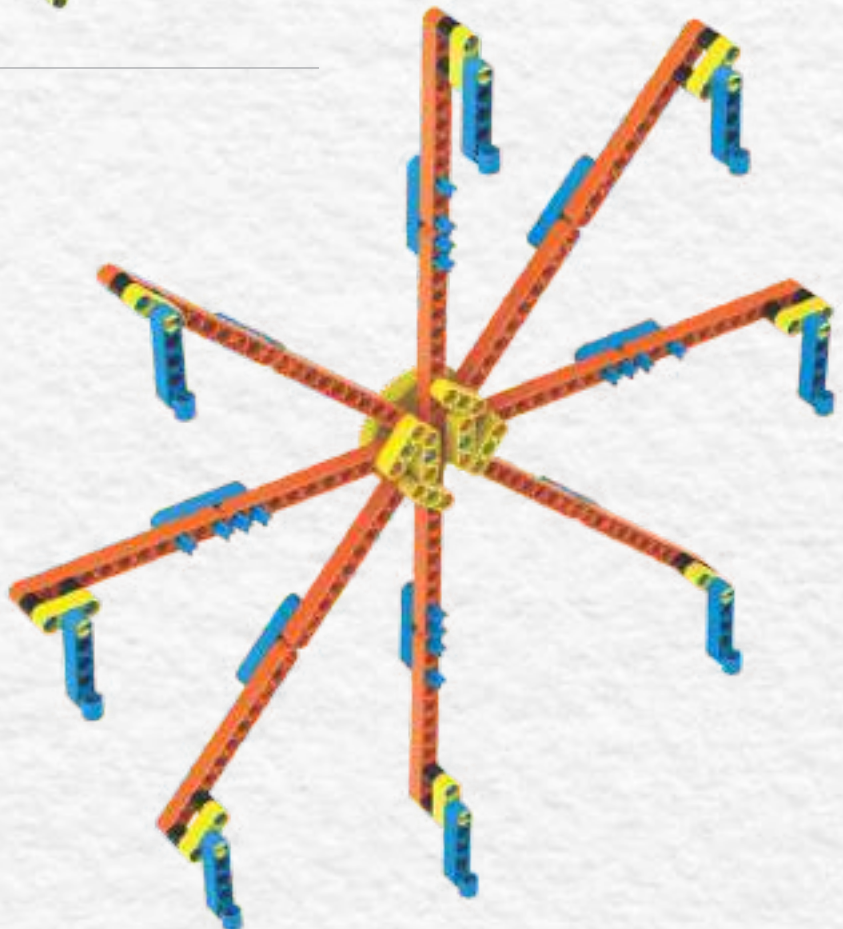

 CH2 8 pcs.

 P5 8 pcs.

Step 15



TW1 8 pcs.



CT3 8 pcs.

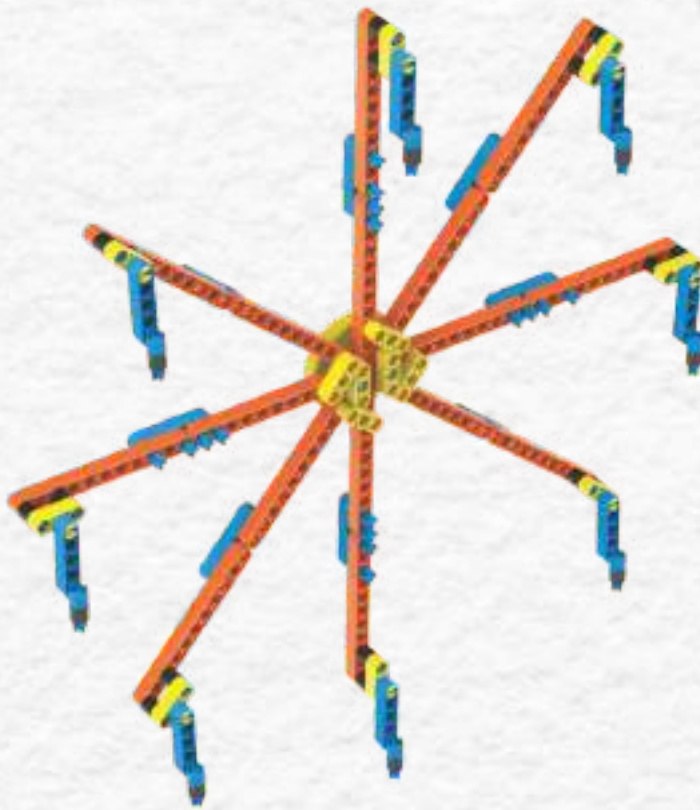

Blix

Step 16

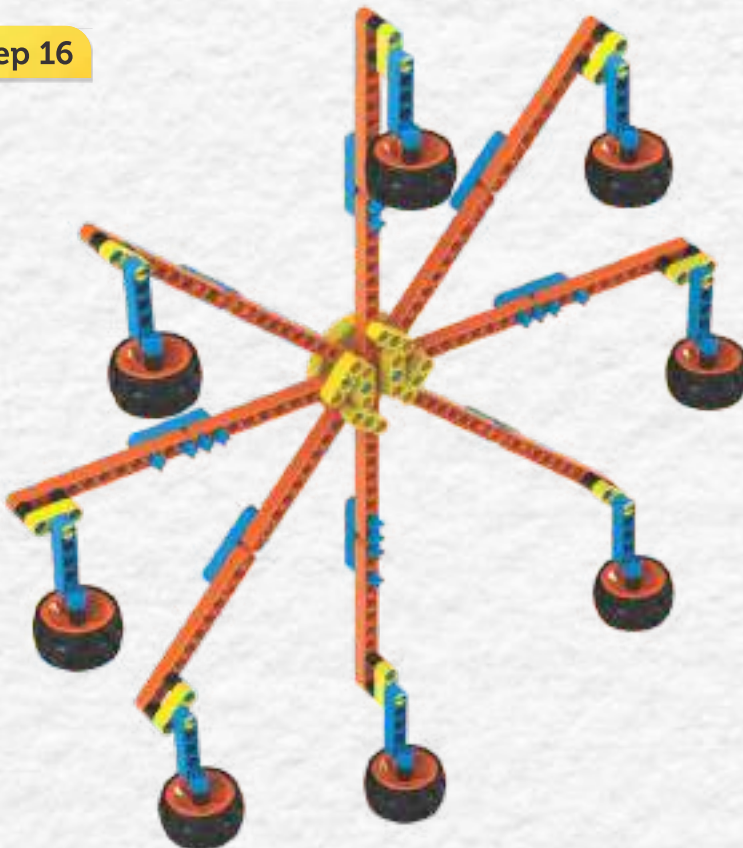

Wheels 8 pcs.

Step 17

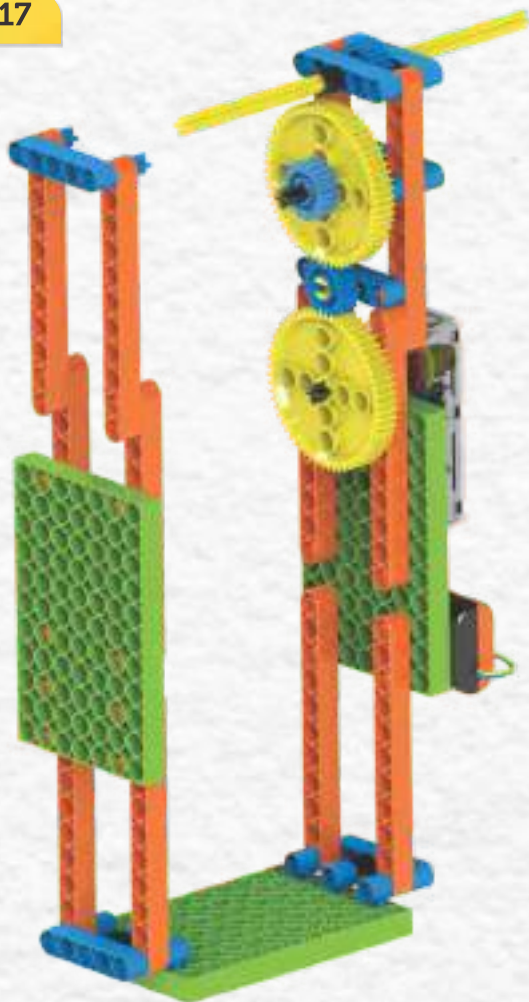

TW1 1 pc.



P5 1 pc.



G(20) 1 pc.

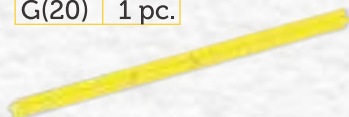

SH170 1 pc.

Step 18



TW1 1 pc.



G(60) 1 pc.



Step 19

Blix

Assembly of Step 18 and Step 16

TW1 7 pcs.



P5 1 pc.



G(20) 1 pc.

Add 7 pcs. of TW1 on the shaft

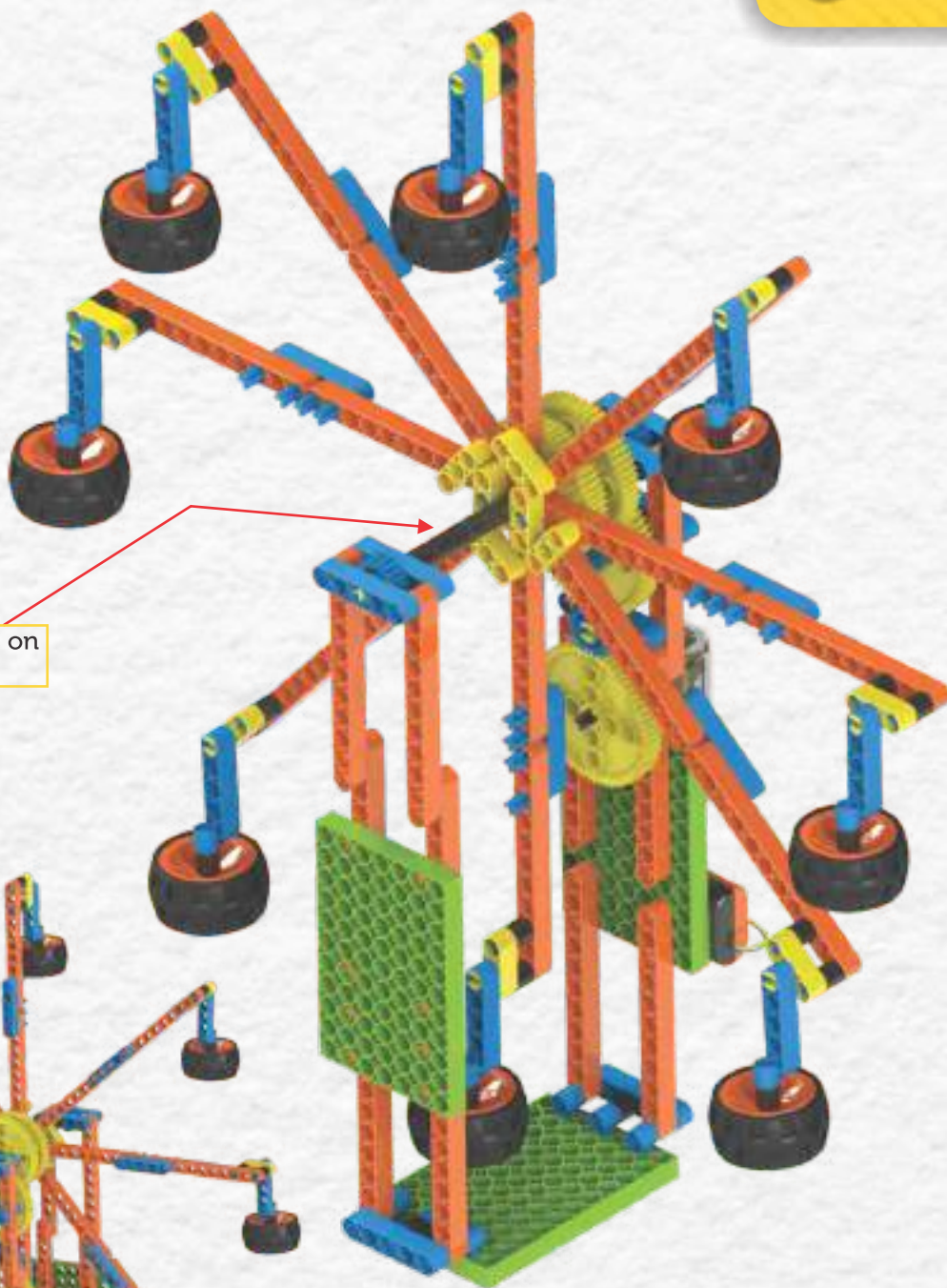

Model 2

Step 1



CT2 2 pcs.

P3 1 pc.

CT3 2 pcs.



TW1 3 pcs.

P7X11 1 pc.

Step 2



P11 1 pc.



CT3 3 pcs.



CH2 8 pcs.



CT2 1 pc.

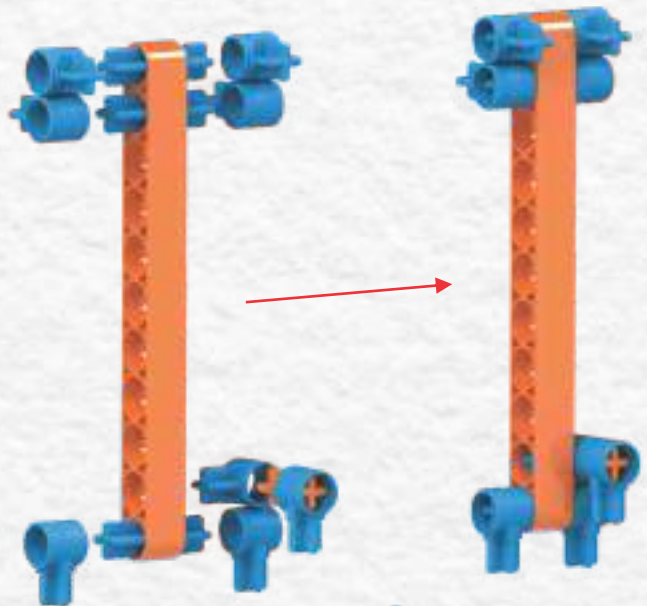

Step 3

Assembly of Step 1 and Step 2



CT2 2 pcs.



P5 1 pc.

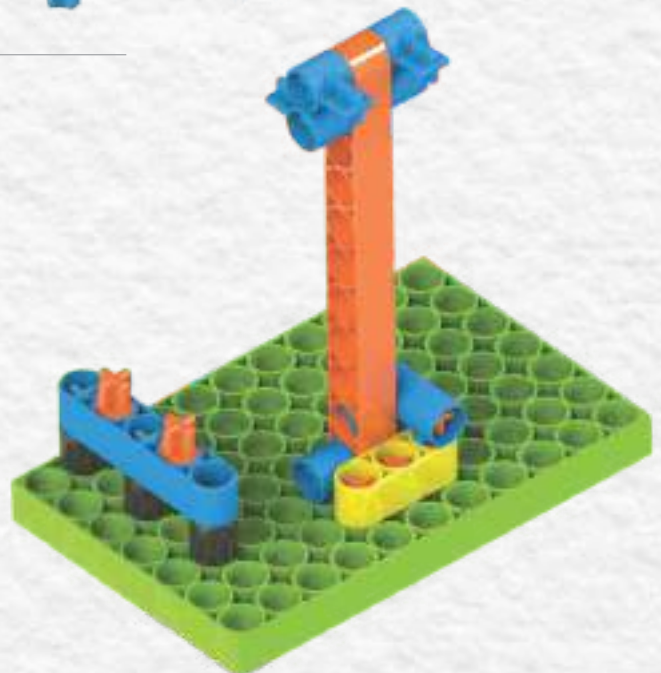

Step 4



CT3 6 pcs.



P5 1 pc.



TW1 4 pcs.



CH2 2 pcs.



P11 2 pcs.

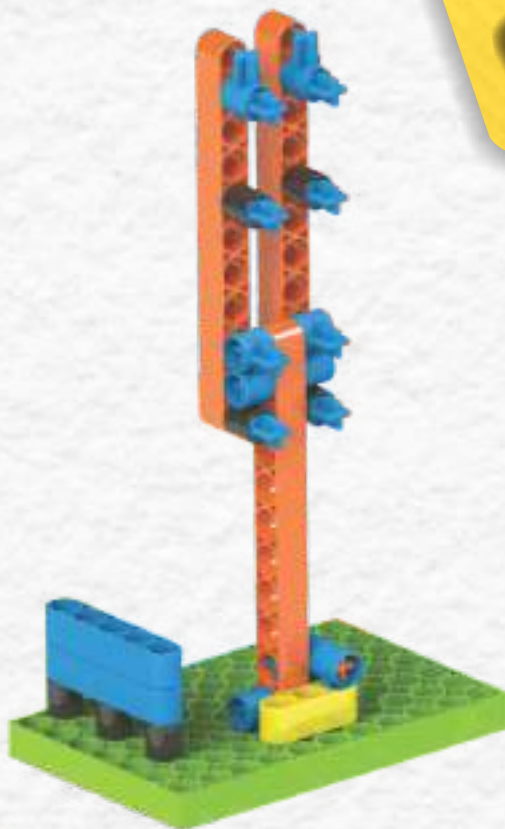

Step 5

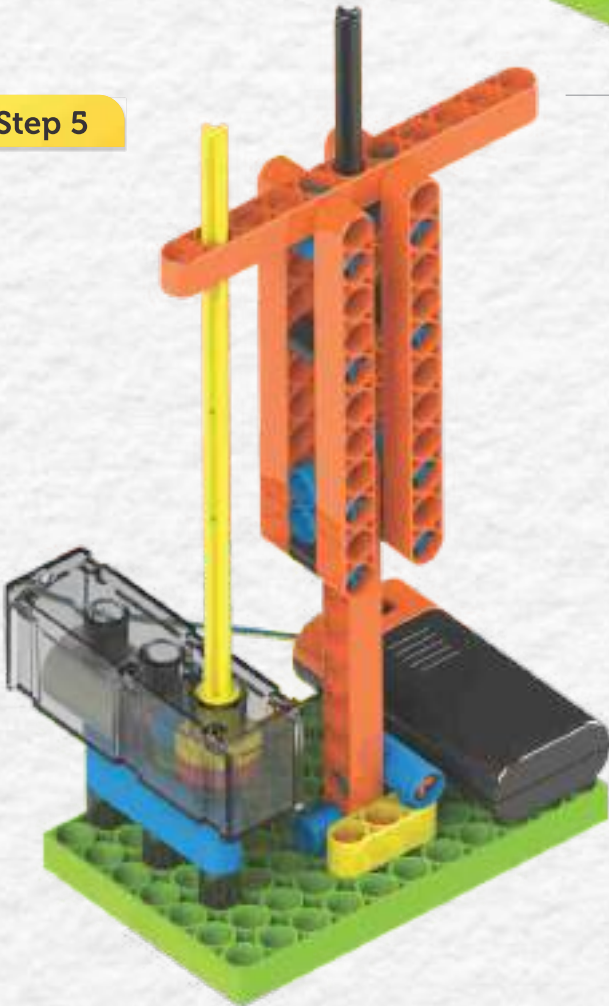

SH60 1 pc.



SH170 1 pc.



P11 3 pcs.



Motor with
Battery Box

Step 6



TW1 2 pcs.



CL2 1 pc.



G(20) 2 pcs.



G(20) Idler 1 pc.



Step 7

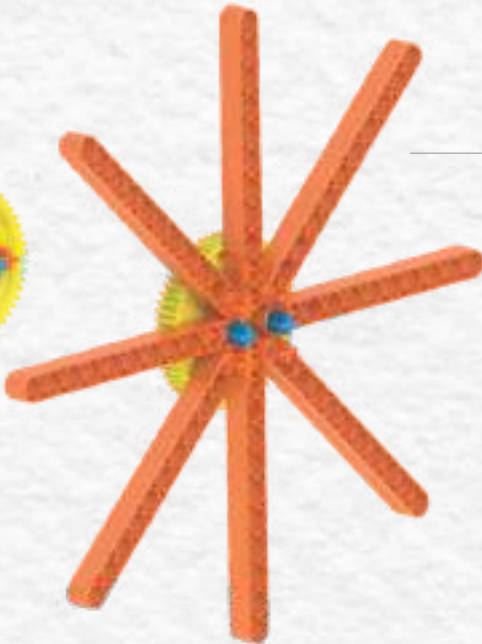

CT3 2 pcs.



CT2 10 pcs.



P11 8 pcs.



G(60) 1 pc.

Step 8



CT2 16 pcs.



P3 2 pcs.

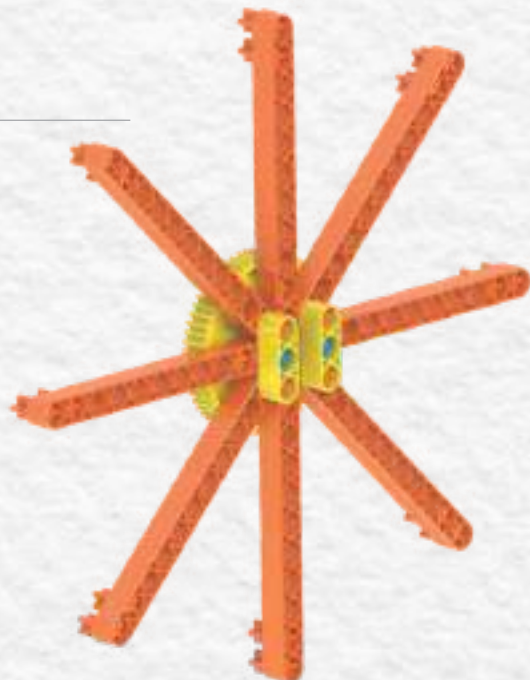

Step 9



CT3 8 pcs.



P5 8 pcs.



Step 10

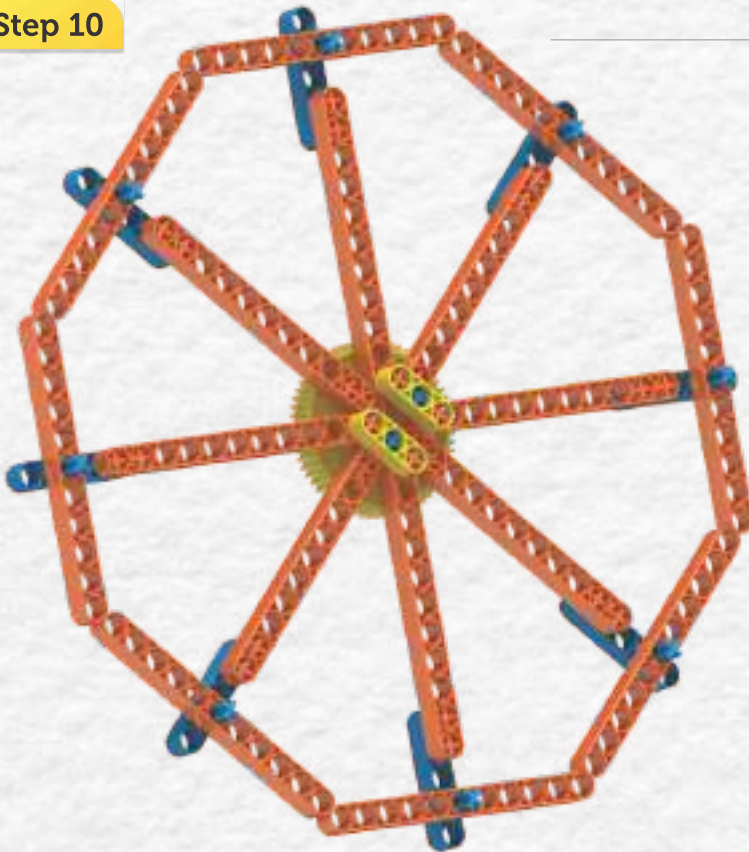

P11 8 pcs.

Step 11



CT2 16 pcs.



CT3 8 pcs.



P3 8 pcs.

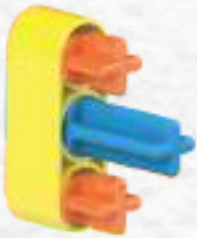

Make 4

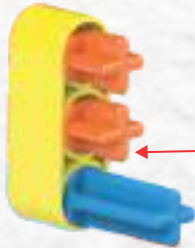

Make 4

Connect alternately with step 10

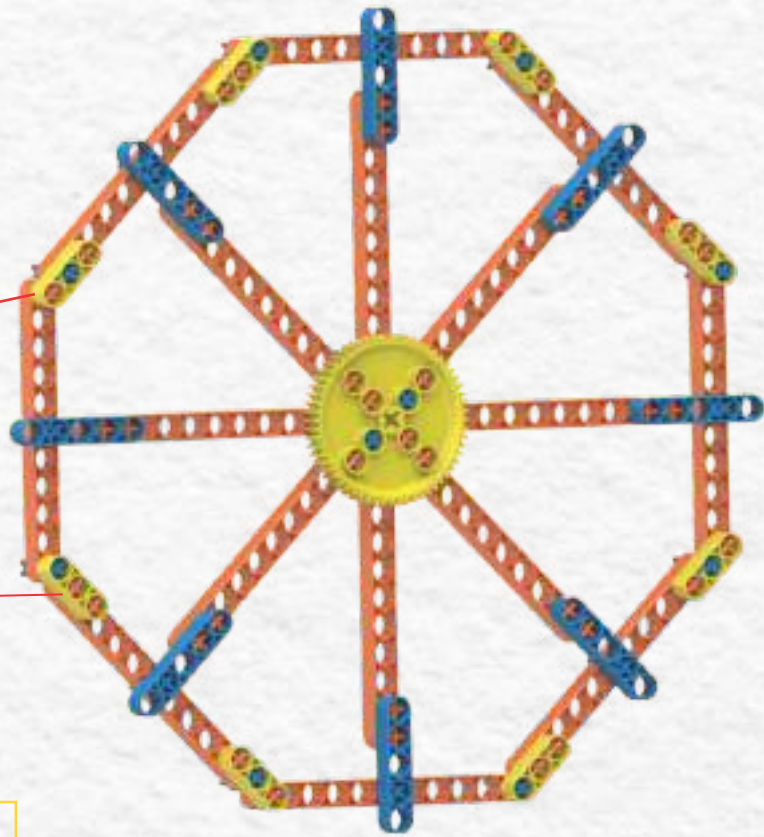

Backside view

Step 12

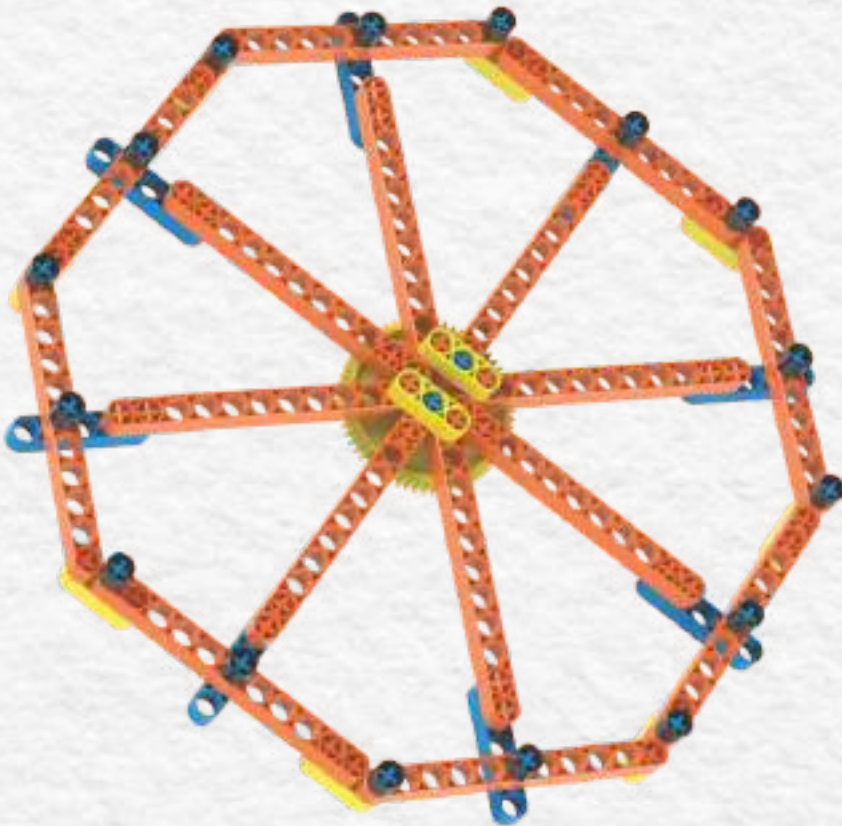

TW1 16 pcs.

Step 13

TW1 8 pcs.

CL2 8 pcs.

CT3 8 pcs.

CH2 16 pcs.

Wheels 8 pcs.

Connect with Step 12

P11 8 pcs.

Make 8

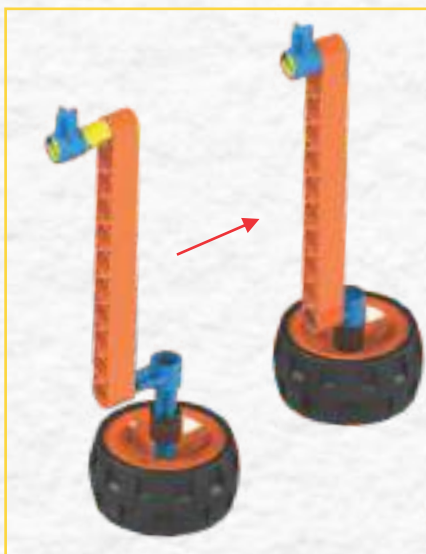

Step 14

Assembly of Step 13 and Step 6

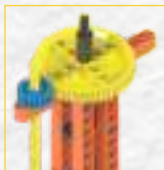

Now replace the gears as shown in figure in step 6 and see what happen! Is there any change in speed?

Model 3

Step 1



CH2 4 pcs.

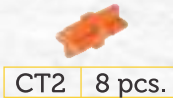

CT2 8 pcs.



CT3 2 pcs.



P7X11 1 pc.



TW1 2 pcs.

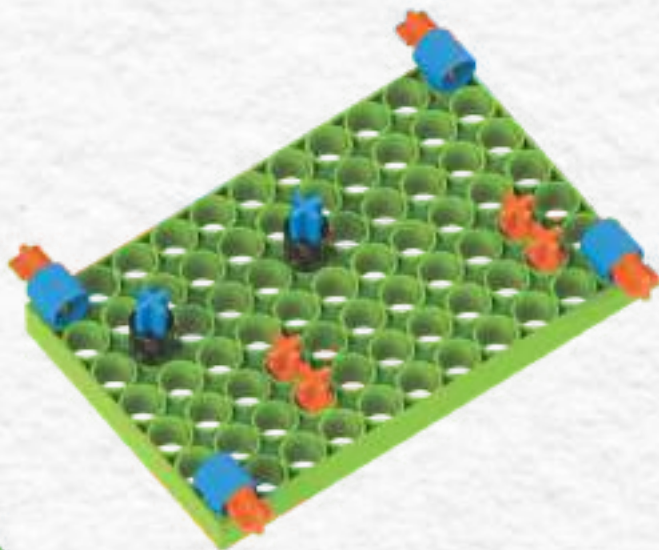

Step 2

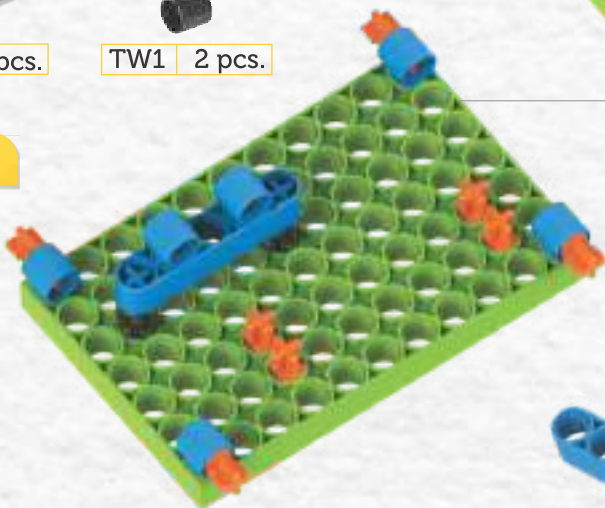

CH2 2 pcs.



P5 1 pc.



Step 3



CT2 4 pcs.



P5 2 pcs.



P7X11 1 pc.

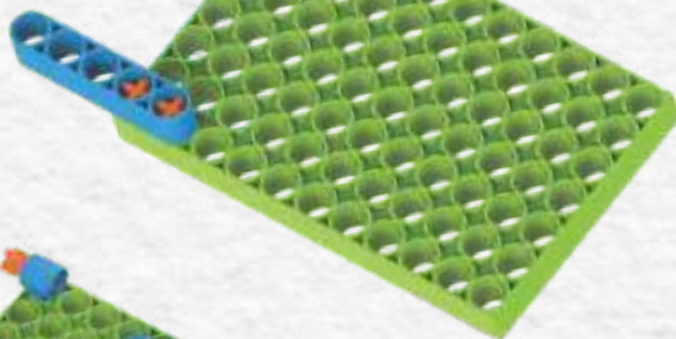

Step 4

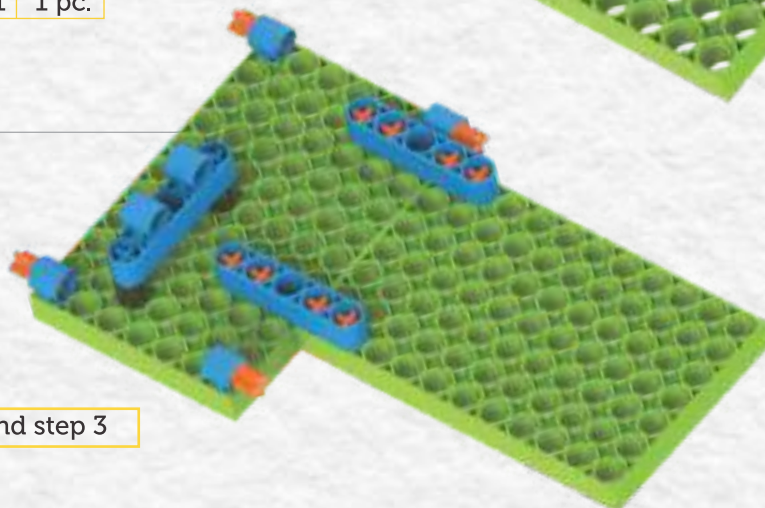

Assembly of step 2 and step 3

Step 5



Motor with
Battery Box



SH60 1 pc.

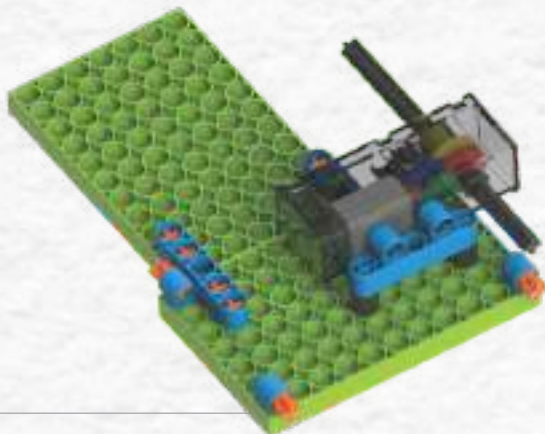

Step 6

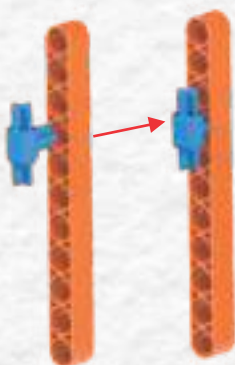

Make 1

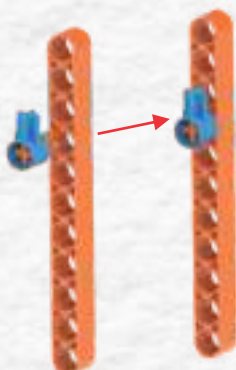

Make 3



CH2 4 pcs.



CT3 1 pc.



CT2 3 pcs.



P11 4 pcs.

Step 7



TW1 2 pcs.

Assembly of step 6 and step 5

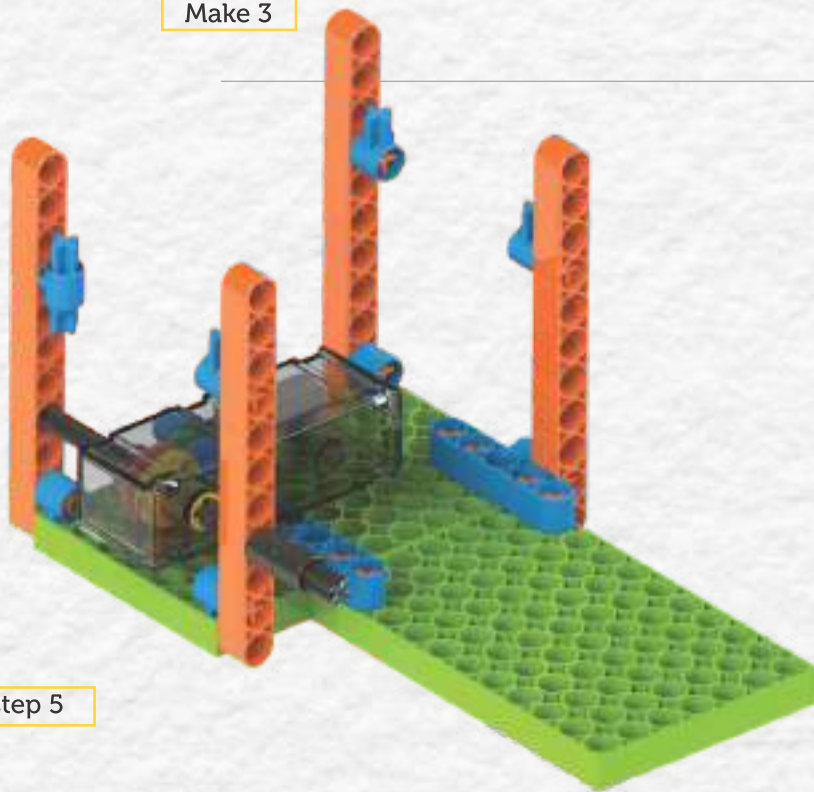

Step 8

CT2 4 pcs.

P3 2 pcs.



P7X11 1 pc.

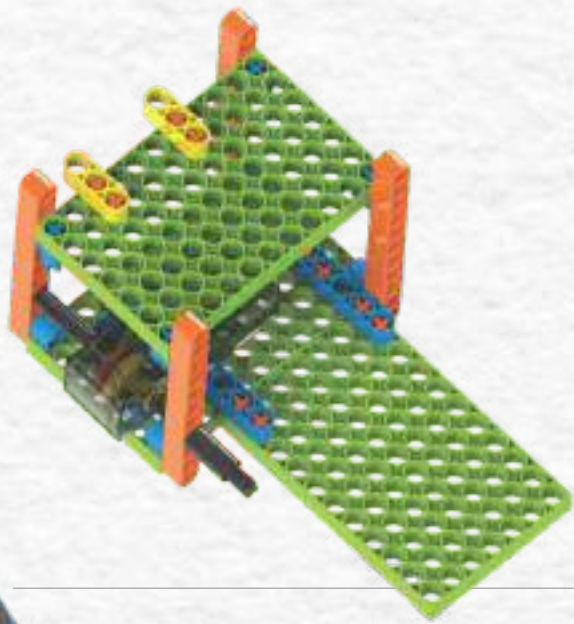

Step 9

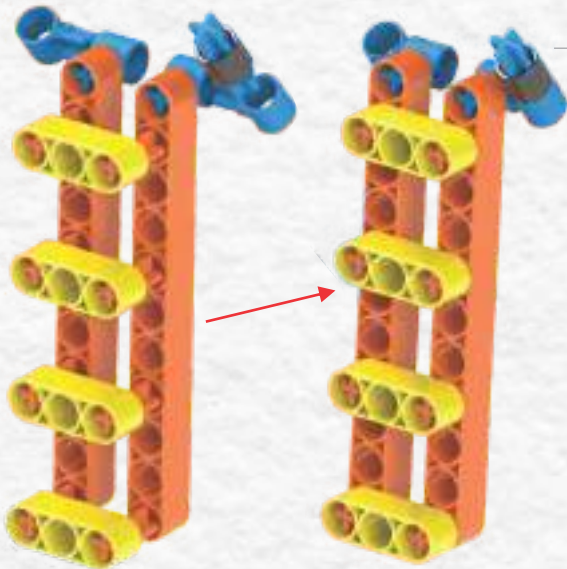

CT2 8 pcs.

P3 4 pcs.

CT3 1 pcs.

TW1 1 pc.

CH2 4 pcs.

P11 2 pcs.



Step 10

Assembly of step 9 and step 8

CL2 1 pc.

G(60) 1 pc.

P5 1 pc.



Push

Step 11

CT2 2 pcs. P5 3 pcs.

CT3 2 pcs. CL2 2 pcs.

TW1 2 pcs. CH2 8 pcs.

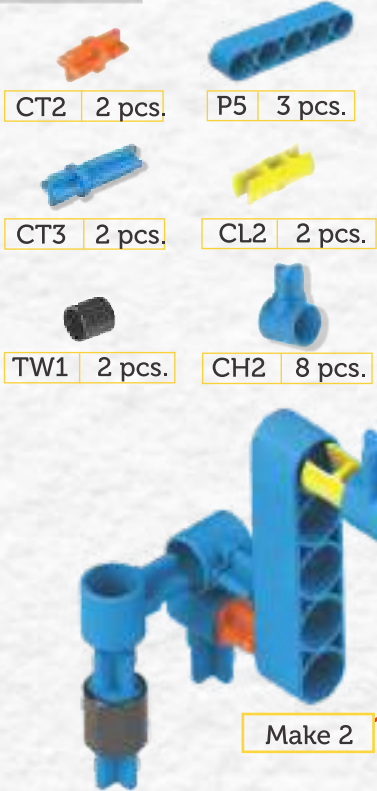

Make 2

This block contains the parts list for Step 11. It lists: CT2 (2 pcs), P5 (3 pcs), CT3 (2 pcs), CL2 (2 pcs), TW1 (2 pcs), and CH2 (8 pcs). Below the list is an exploded view of the assembly for this step, showing two identical units. Red arrows point from the 'Make 2' label to the two units. The units are constructed from blue Technic beams and connectors, with some yellow and black components.

Step 12

Assembly of step 11 and step 10

Attach step 18 on these holes

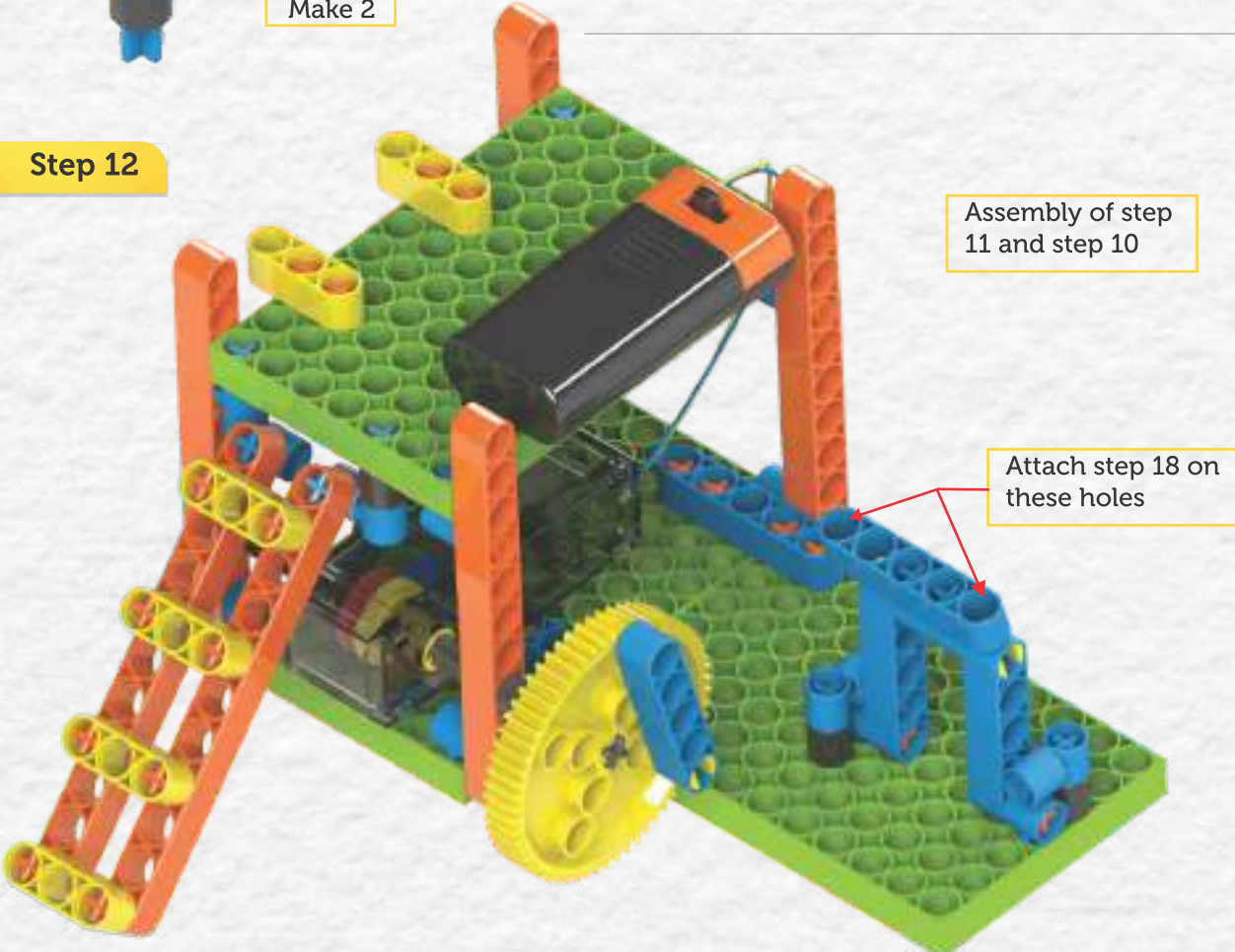

This block shows the assembly for Step 12. It features a green Technic base plate with a motor and a yellow gear. Two orange vertical beams are attached to the base. A blue Technic beam is attached to the base, and two units from Step 11 are attached to it. Red arrows point from the 'Attach step 18 on these holes' label to two holes on the blue beam. The 'Assembly of step 11 and step 10' label points to the units from Step 11.

Step 13

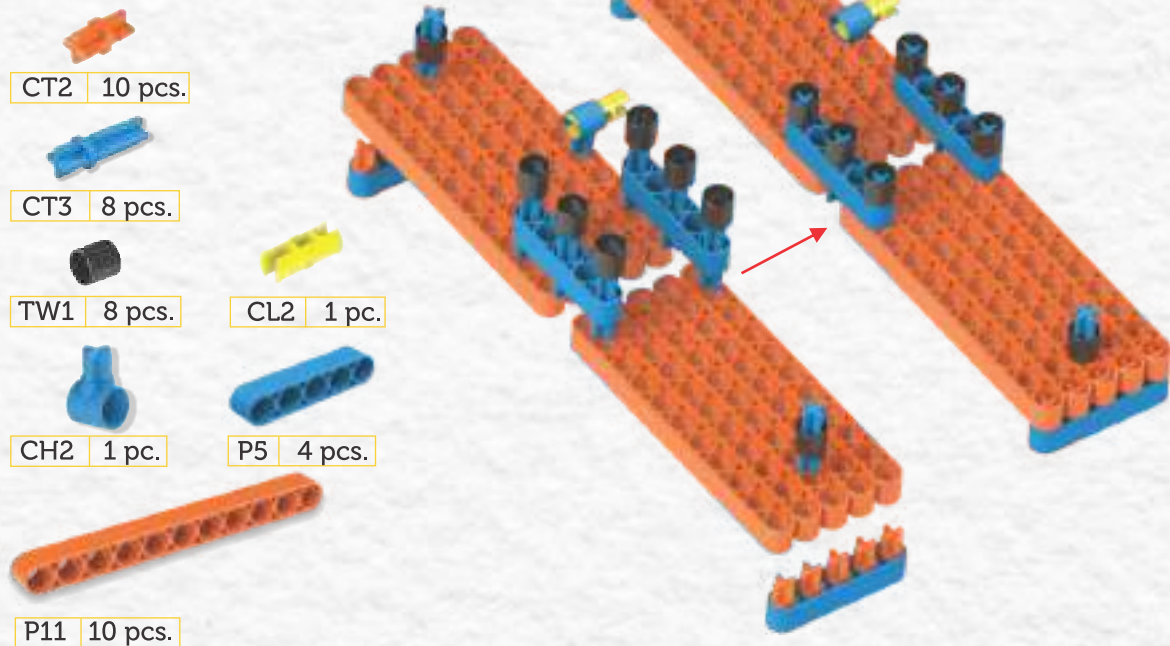

Step 14

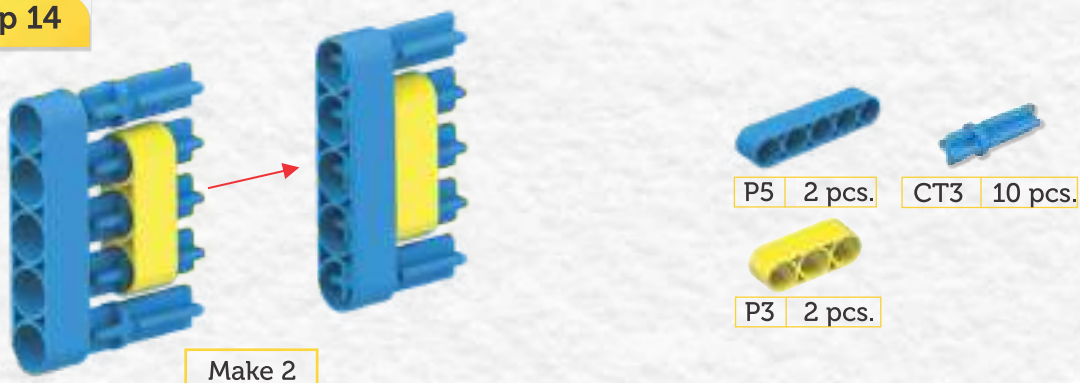

Step 15

Assembly of step 14 and step 13

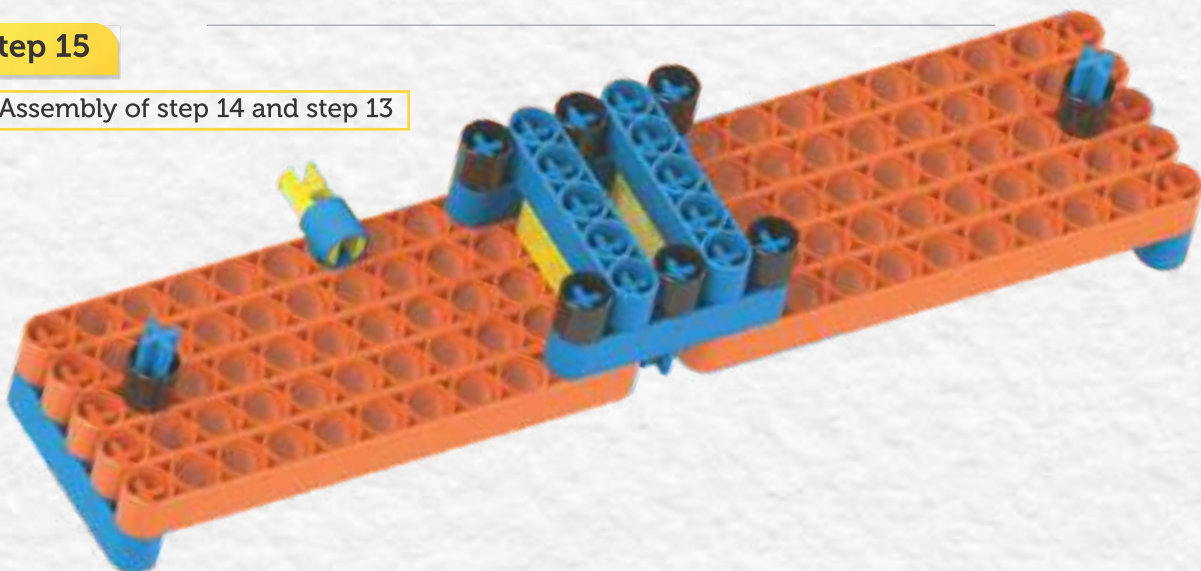

Step 16

CT2 4 pcs.

CT3 2 pcs.

CH2 4 pcs.

TW1 2 pcs.

P5 4 pcs.

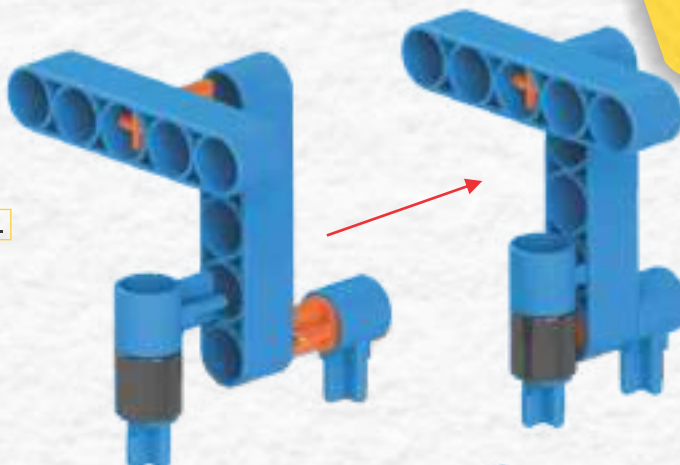

Make 2

Step 17

Assembly of step 16 and step 15

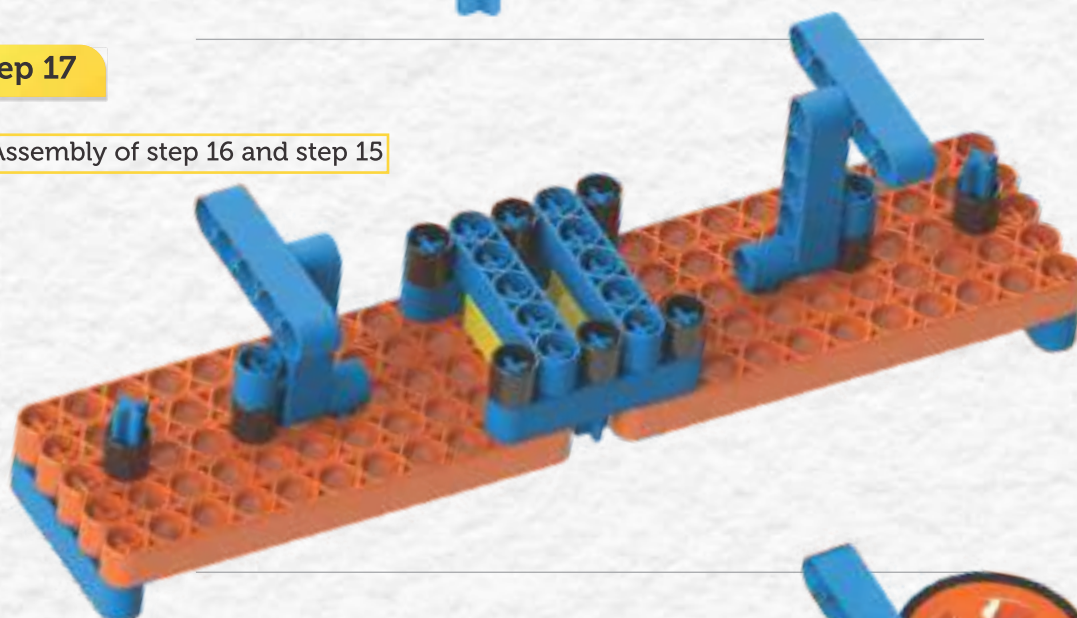

Step 18

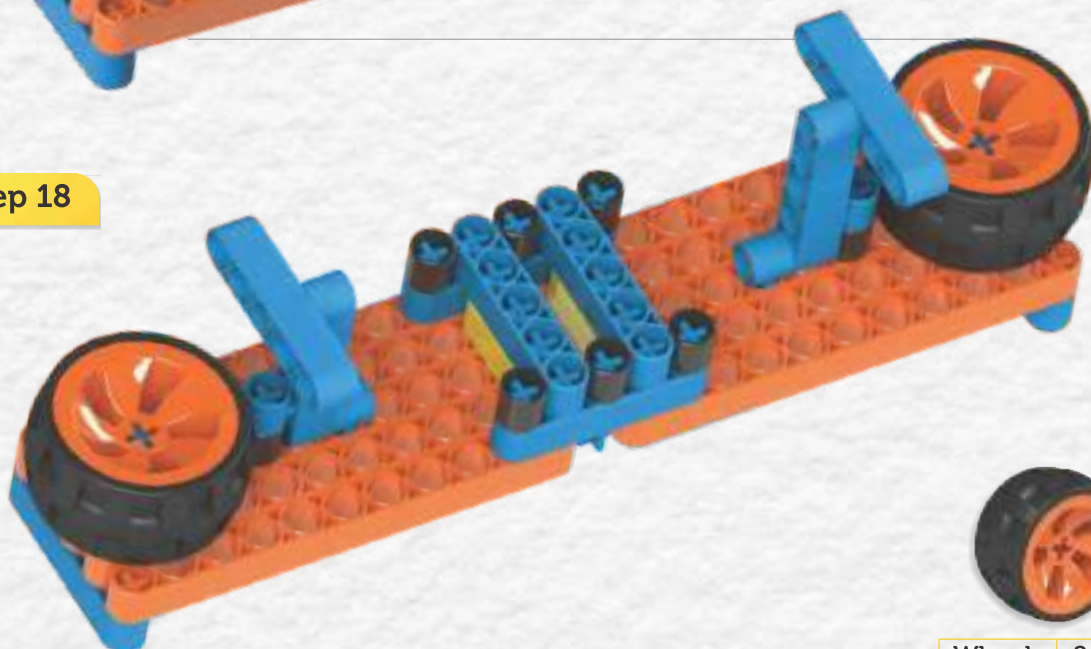

Wheels 2 pcs.

Step 19

Assembly of step 18 and step 12

Attach step 22 on these holes

Connect CL2 with P5

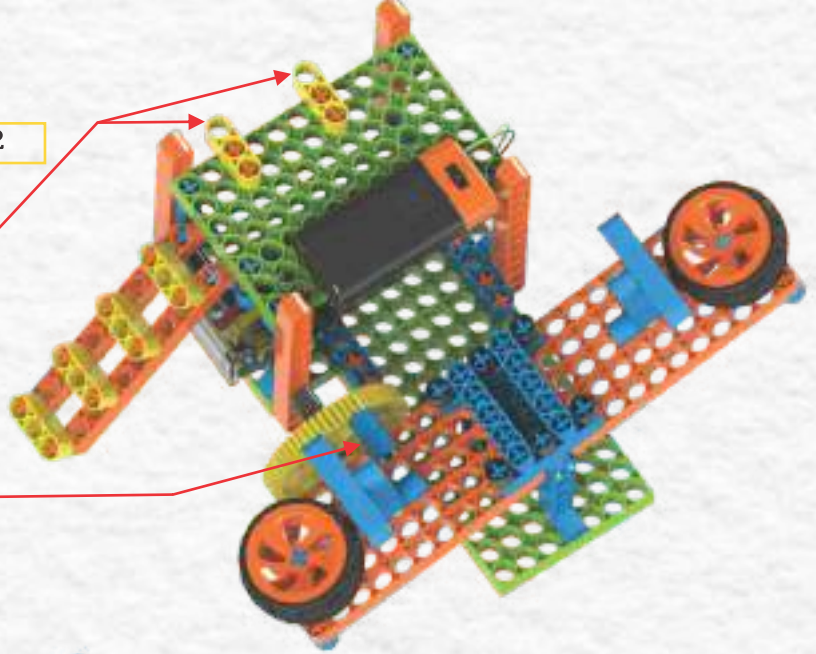

Step 20

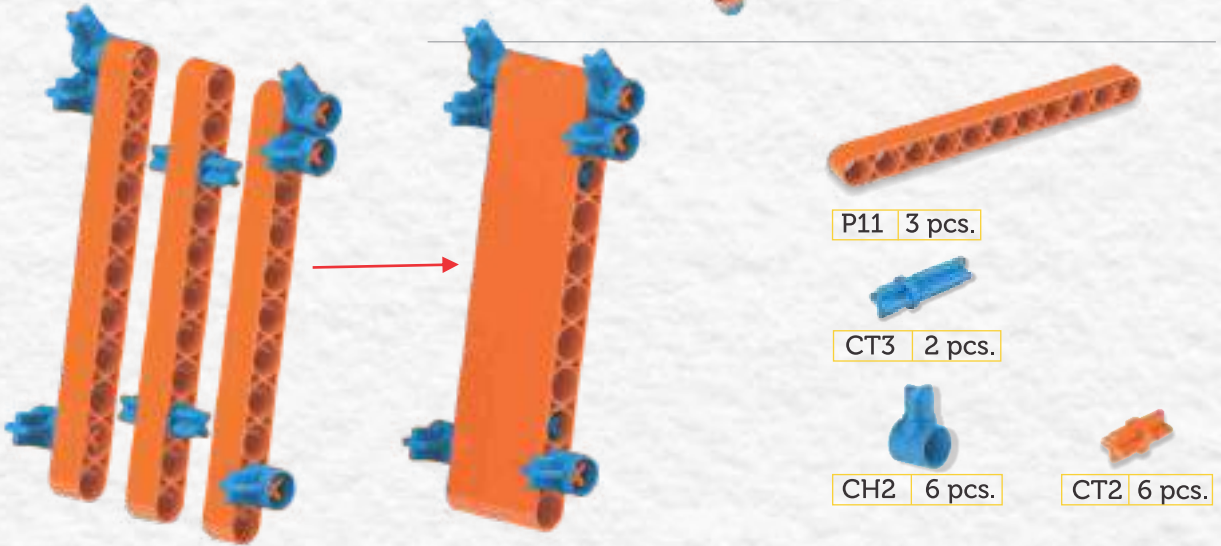

Step 21

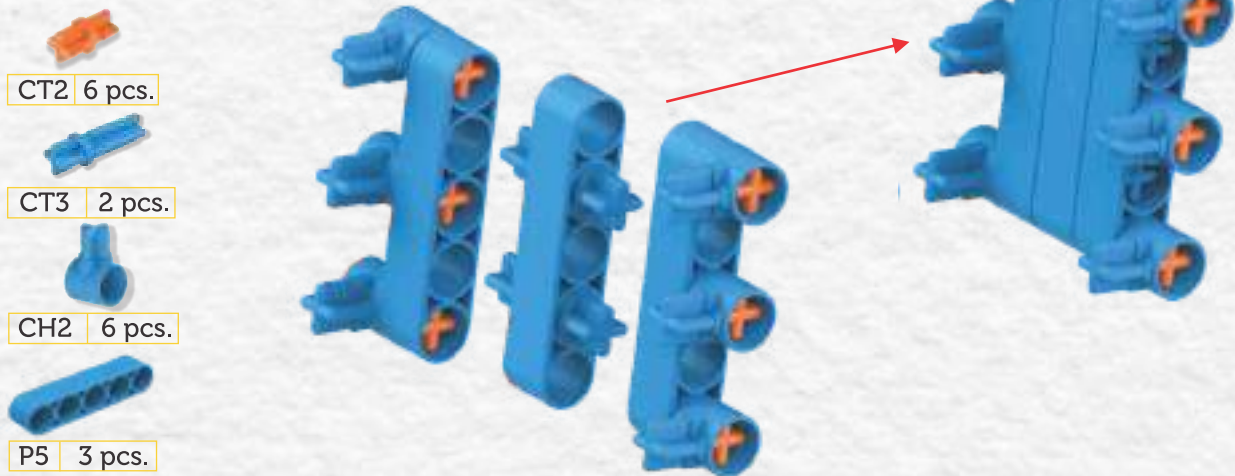

Step 22



P11 2 pcs.



P3 2 pcs.

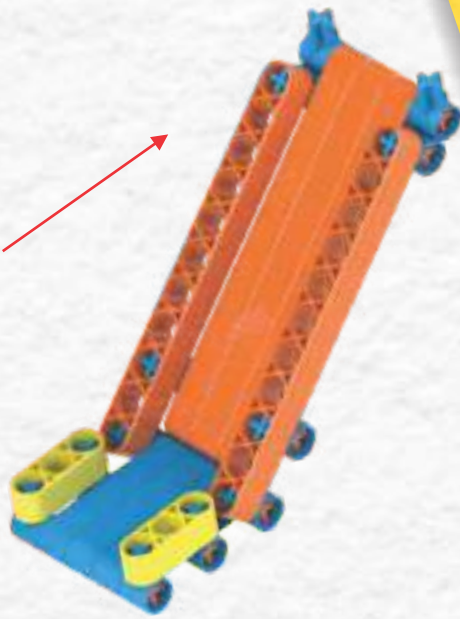
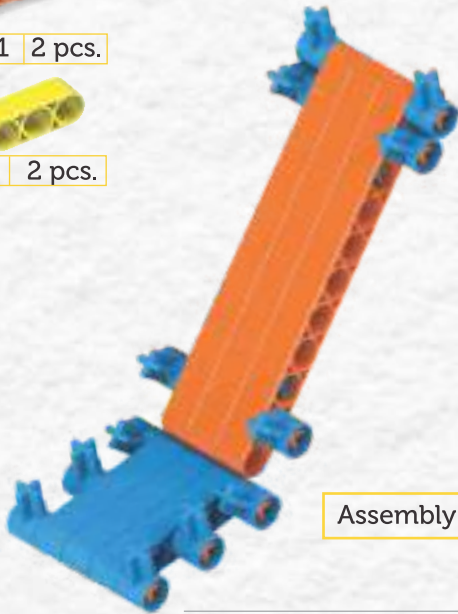

Assembly of step 21 and step 20

Step 23



Assembly of step 22 and step 19

Blix

Model 4

Step 1



CT2 2 pcs.



P7X11 1 pc.

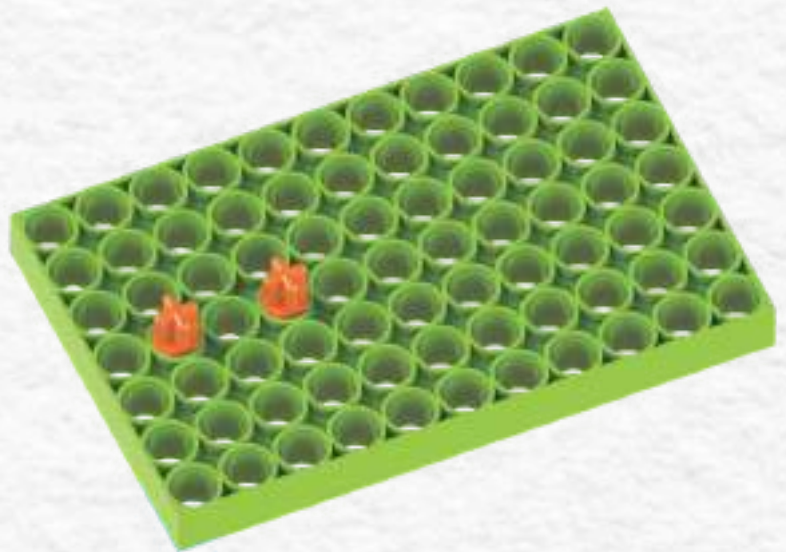

Step 2

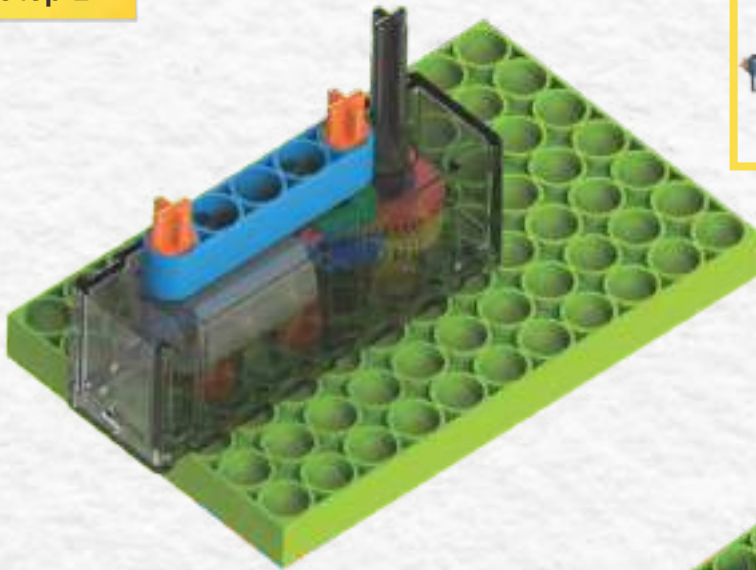

CT2 2 pcs.



Motor with
Battery Box



P5 1 pc.

Step 3



P7X11 1 pc.



CT2 12 pcs.



Step 4



P3 4 pcs.



P5 4 pcs.



Step 5



CT2 20 pcs.

Step 6



CL2 4 pcs.



P5 4 pcs.



P11 6 pcs.

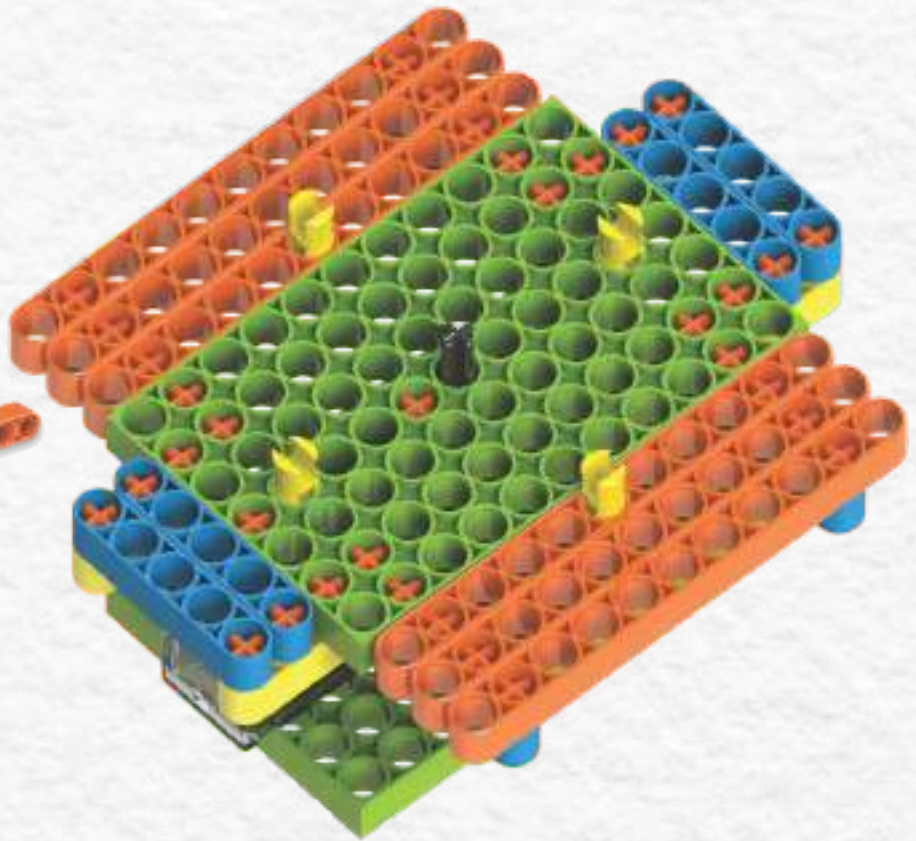

Step 7



G(60) 1 pc.



G(20) Idler 4 pcs.



CT3 4 pcs.



TW1 4 pcs.

Step 8



CT2 8 pcs.



P11 3 pcs.



Step 9



CT2 4 pcs.



P11 3 pcs.

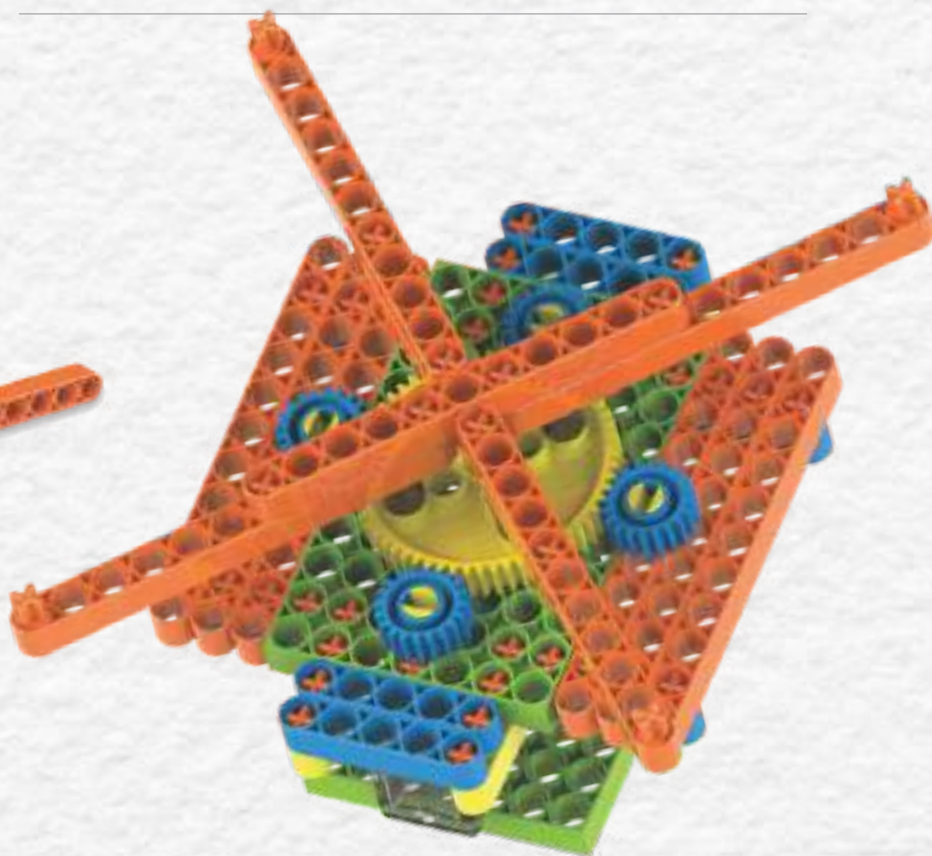

Step 10



CH2 2 pcs.



CT2 2 pcs.



TW1 2 pcs.



SH60 4 pcs.



G(20) 4 pcs.

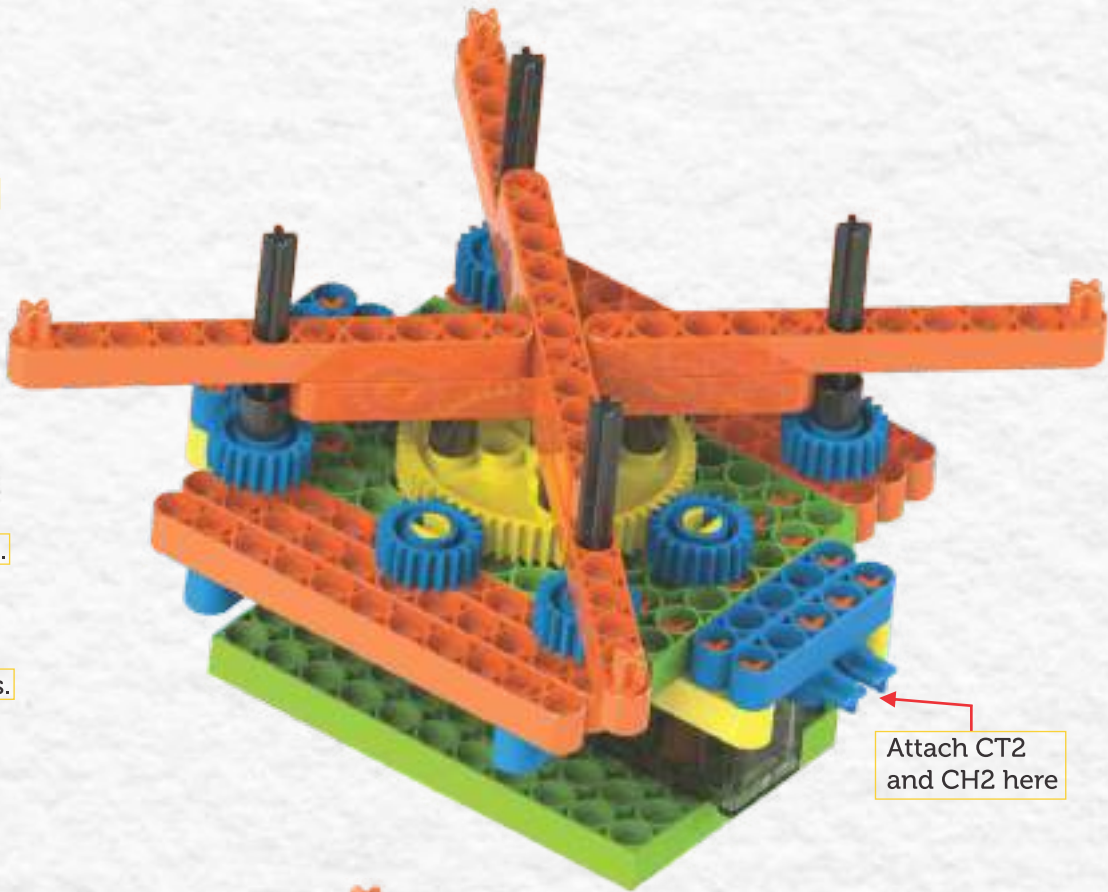

Attach CT2
and CH2 here

Step 11

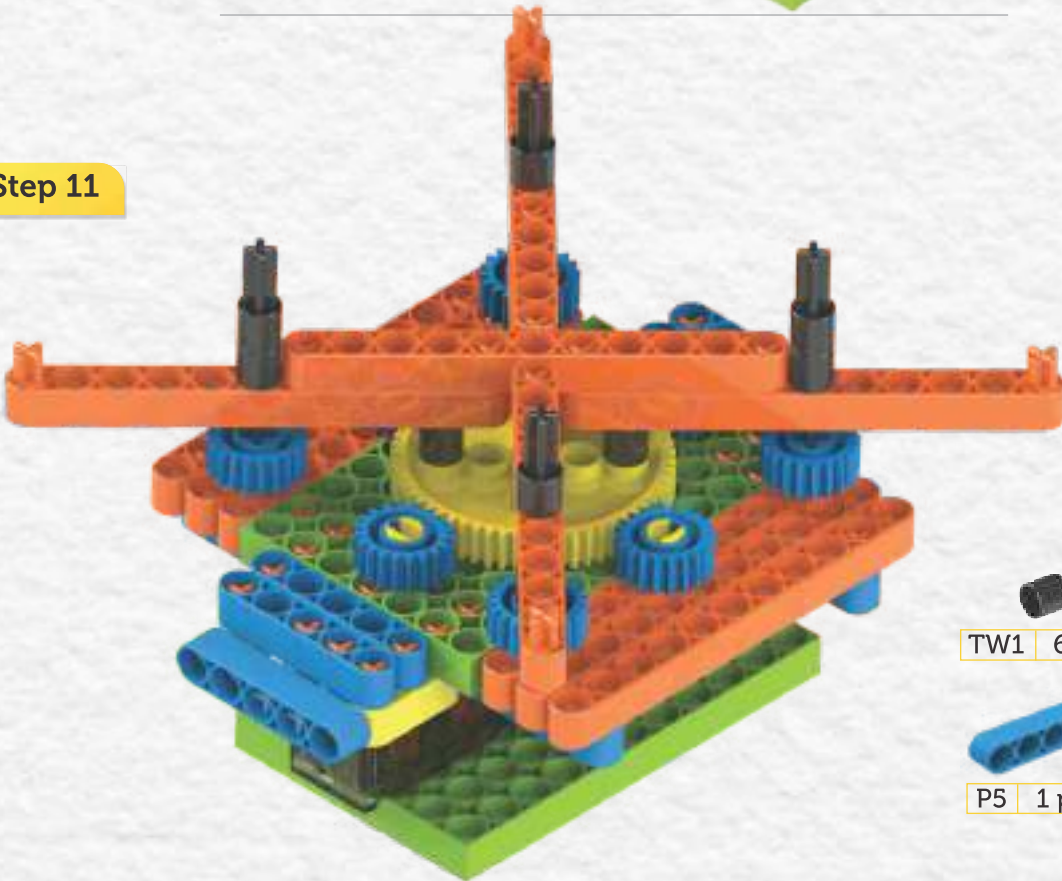

TW1 6 pcs.

P5 1 pcs.

Step 12



P5 4 pcs.



Blix

Step 13



Wheels 4 pcs.



Model 5

Step 1

CT2 1 pc.

P3 1 pc.



Motor with
Battery Box

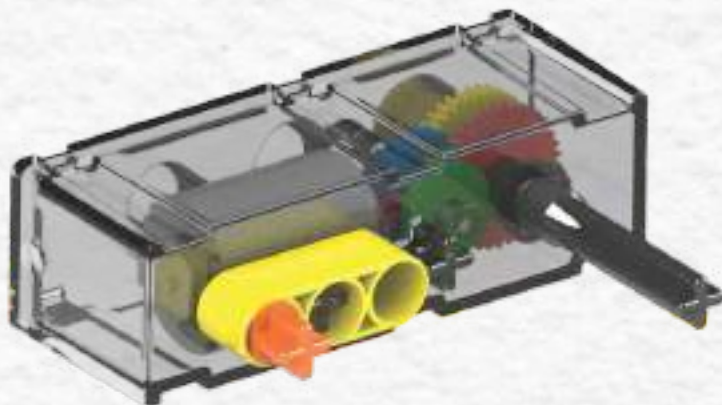

Step 2

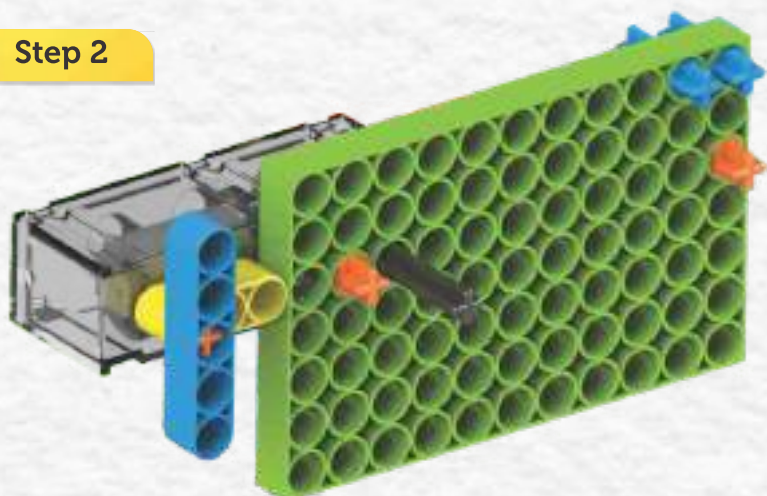

CT2 2 pcs.



P7X11 1 pc.

CT3 2 pcs.



P5 1 pc.

Step 3

CL2 2 pcs.

SH60 1 pc.

P5 1 pc.

P11 1 pc.

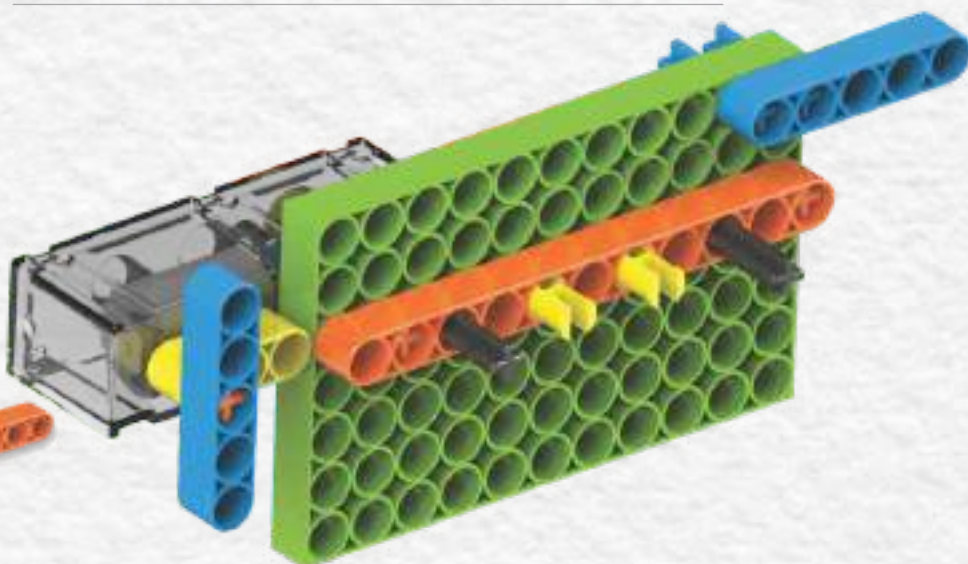

Step 4

Blix

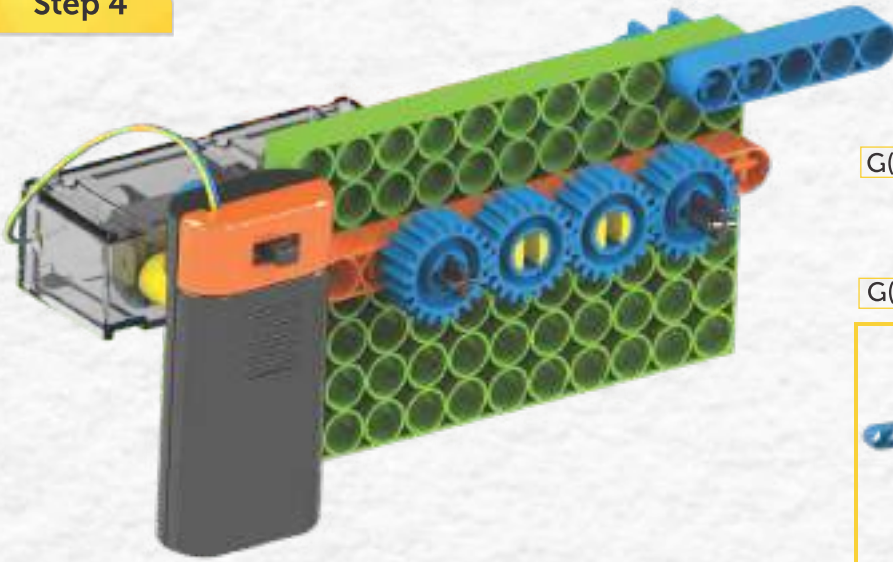

G(20) 2 pcs.



G(20) Idler 2 pcs.

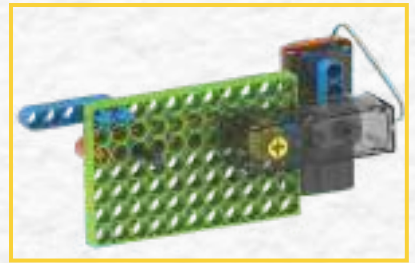

Step 5



CL2 2 pcs.



G(60) 1 pc.



P5 1 pc.



Step 6



CT2 4 pcs.



CT3 3 pcs.



TW1 1 pc.



Step 7



P3 1 pc.



CT3 2 pcs.



P5 2 pcs.



P11 2 pcs.

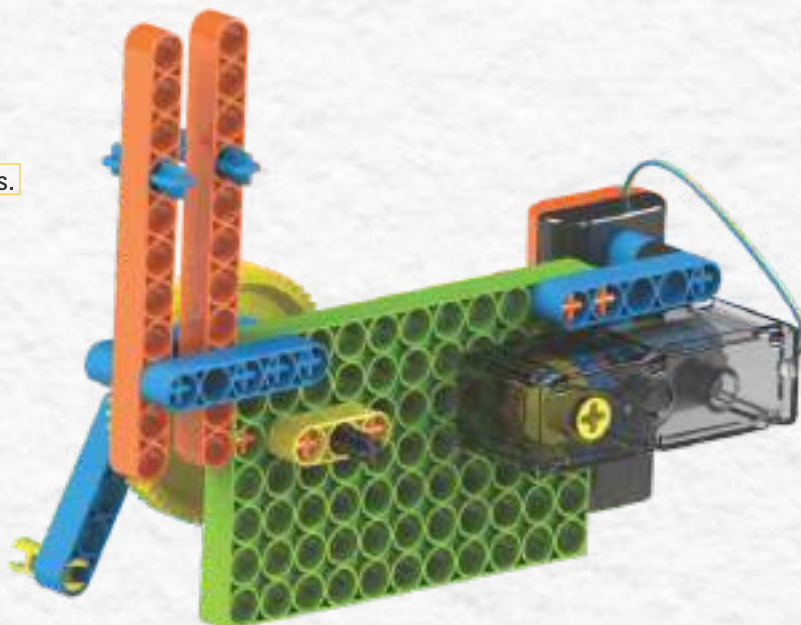

Step 8

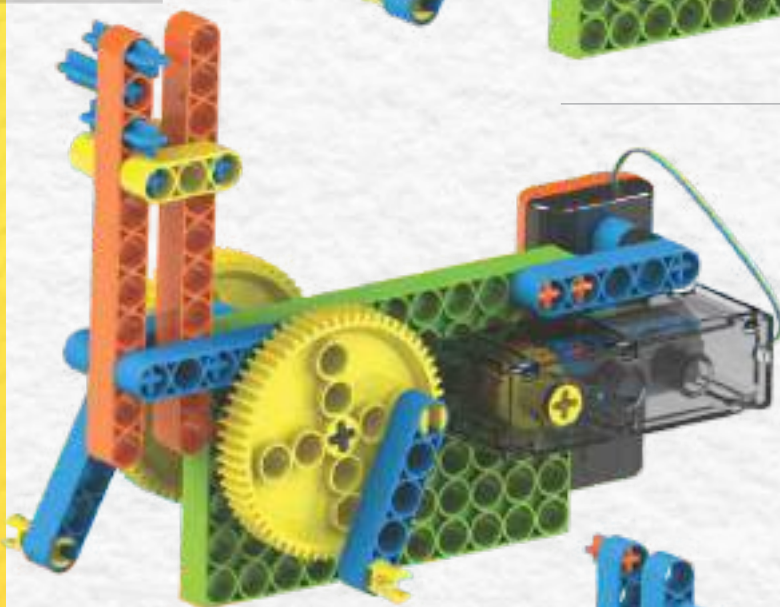

CL2 2 pcs.



CT3 3 pcs.



G(60) 1 pc.



P3 2 pcs.



P5 1 pc.

Step 9



CT2 2 pcs.



CT3 1 pc.



CH2 2 pc.



P5 2 pcs.

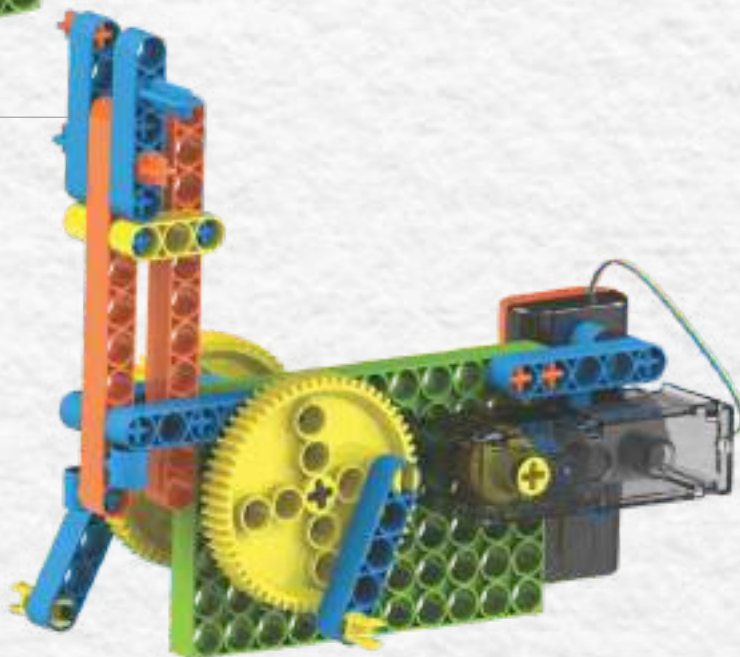

Step 10

TW1 2 pcs.

CT2 1 pc.

CT3 4 pcs. P5 2 pcs.

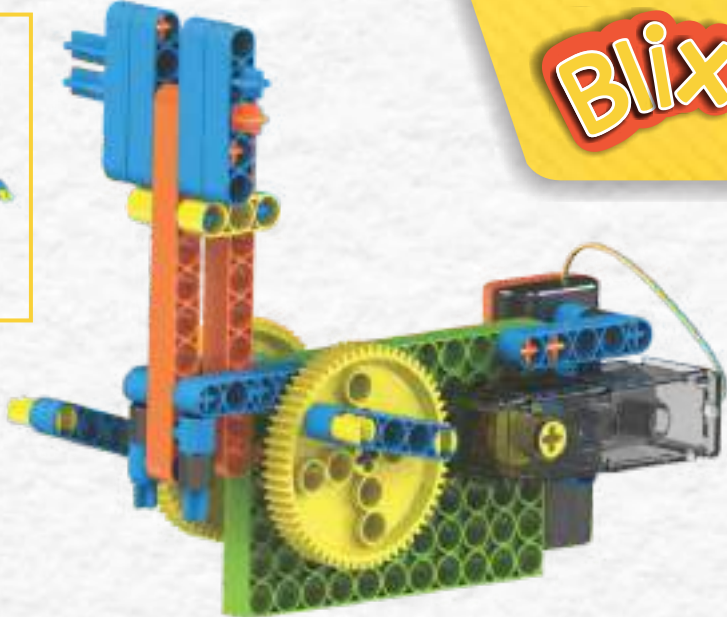

Step 11

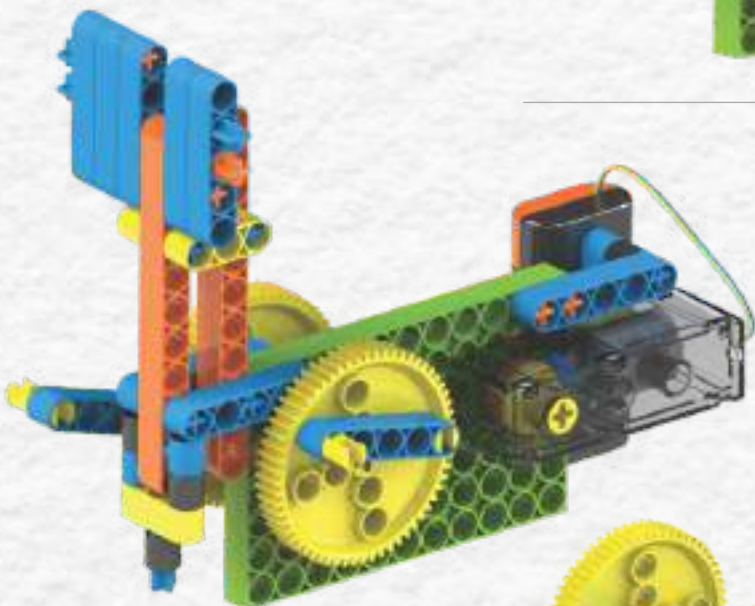

TW1 1 pc.

CT3 1 pc.

P3 1 pc.

P5 1 pc.

Step 12

G(60) 2 pcs.

Wheels 1 pc.

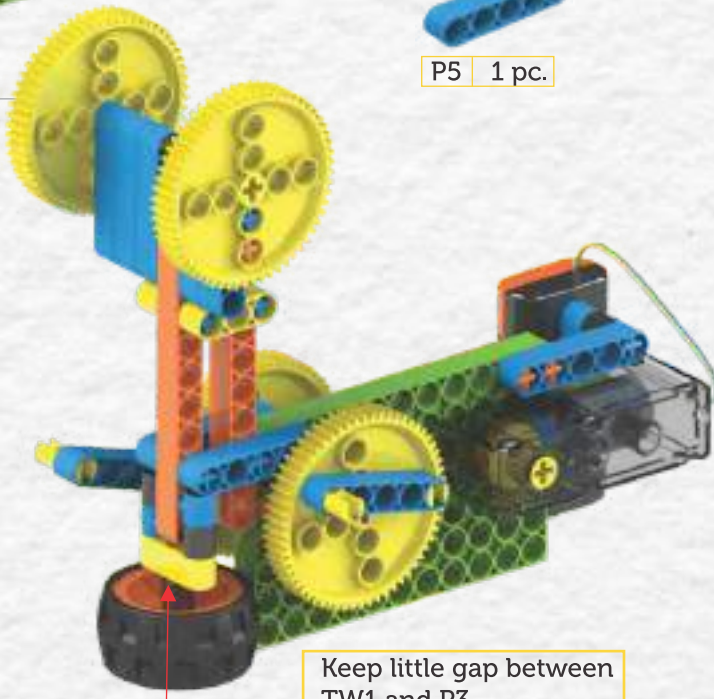

Keep little gap between TW1 and P3

Step 13



CT2 4 pcs.



CH2 4 pcs.



P7X11 1 pc.

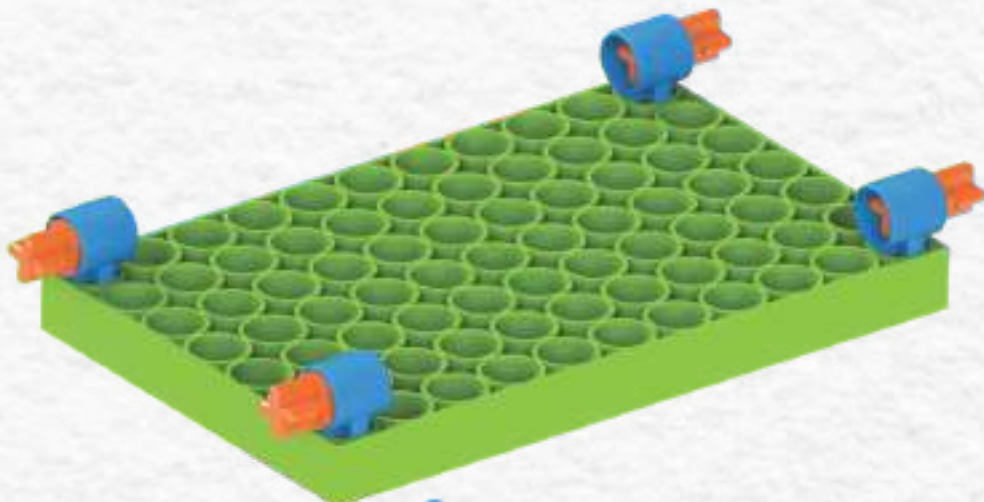

Step 14

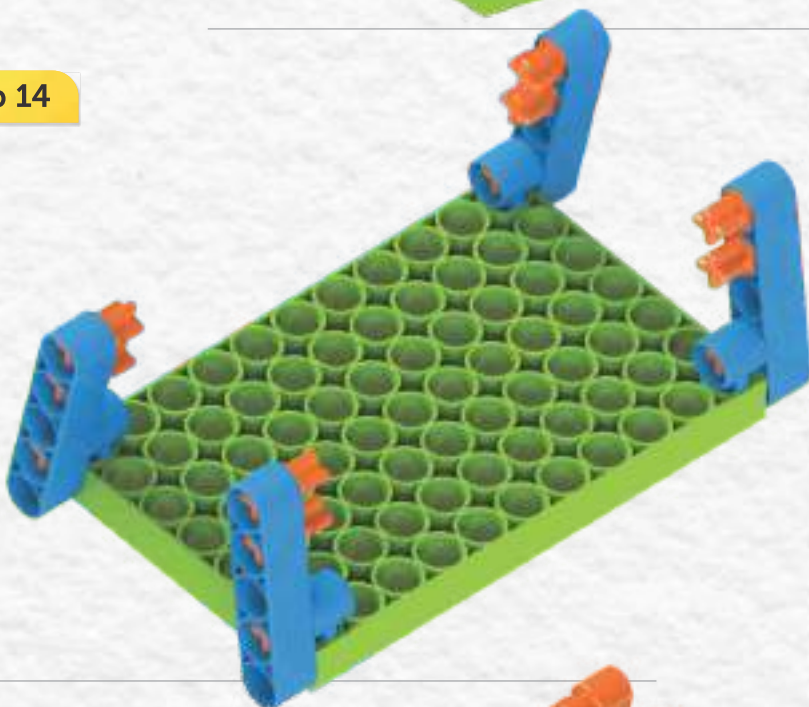

CT2 8 pcs.



P5 4 pcs.

Step 15



CT2 4 pcs.



P11 4 pcs.

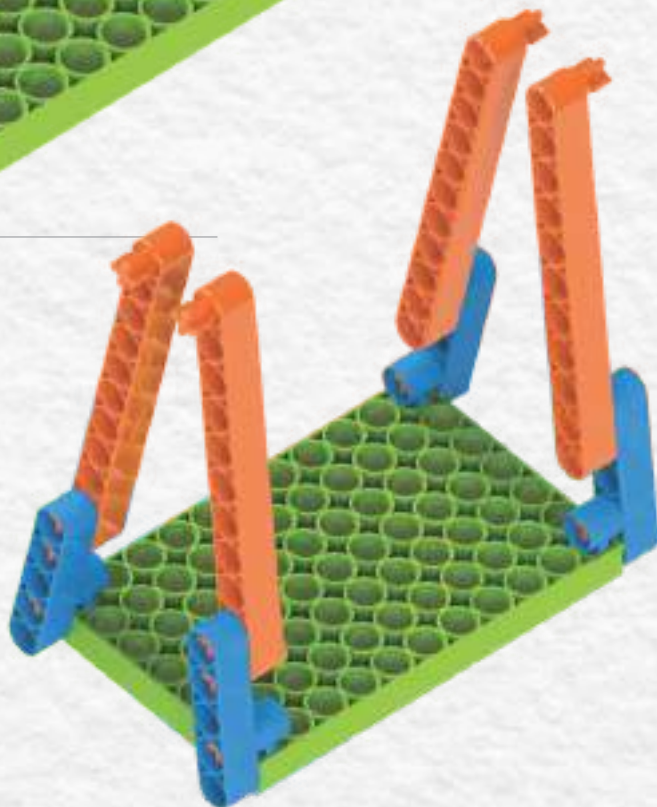

Step 16

 CH2 2 pcs.

 P3 2 pcs.

 SH170 1 pc.

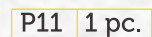
 P11 1 pc.

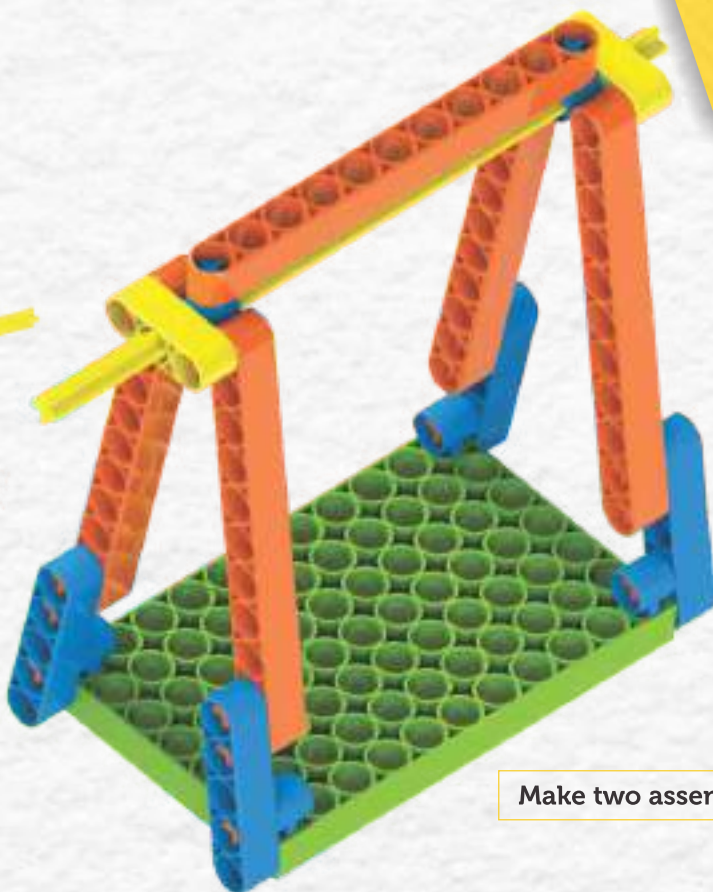

Make two assemblies

Step 17

 TW1 3 pcs.

 CT2 1 pc.

 CT3 3 pcs.

 P11 1 pc.

 Wheels 2 pcs.

 CH2 3 pcs.

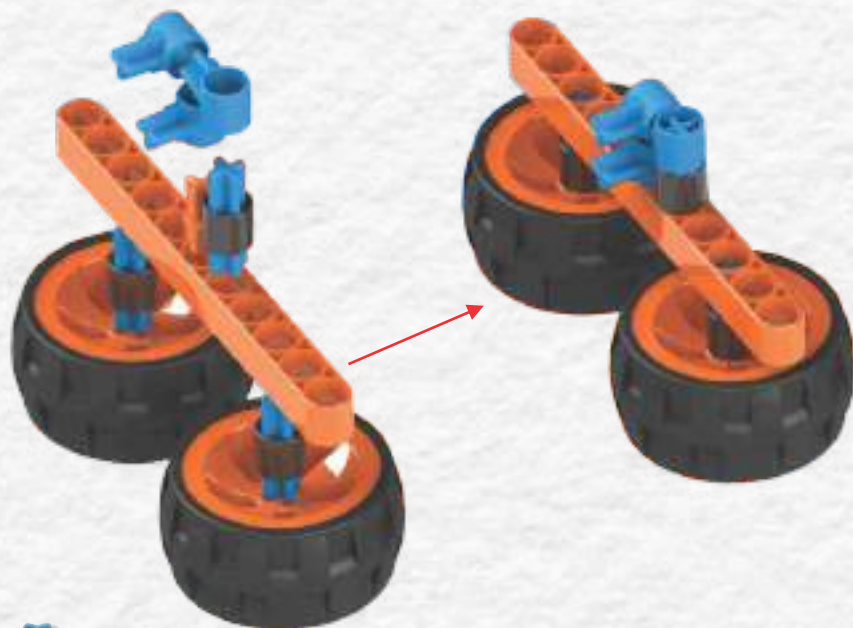

Step 18



TW1 4 pcs.

CT3 4 pcs.

P5 1 pc.

P11 2 pcs.

Step 19

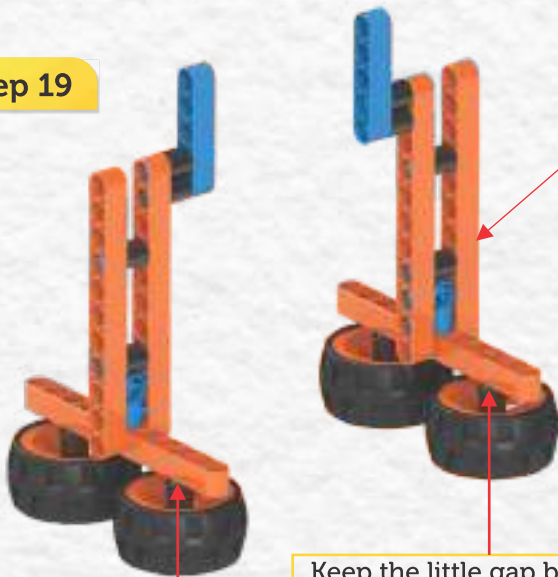

Make step 18 but connect this piece on backside

Keep the little gap between TW1 and P11

Step 20

Assembly Of Step 18 and Step 16



Step 21

Assembly of step 19 and 16



Blix

Step 22

Assembly of step 20, step 21 and step 12

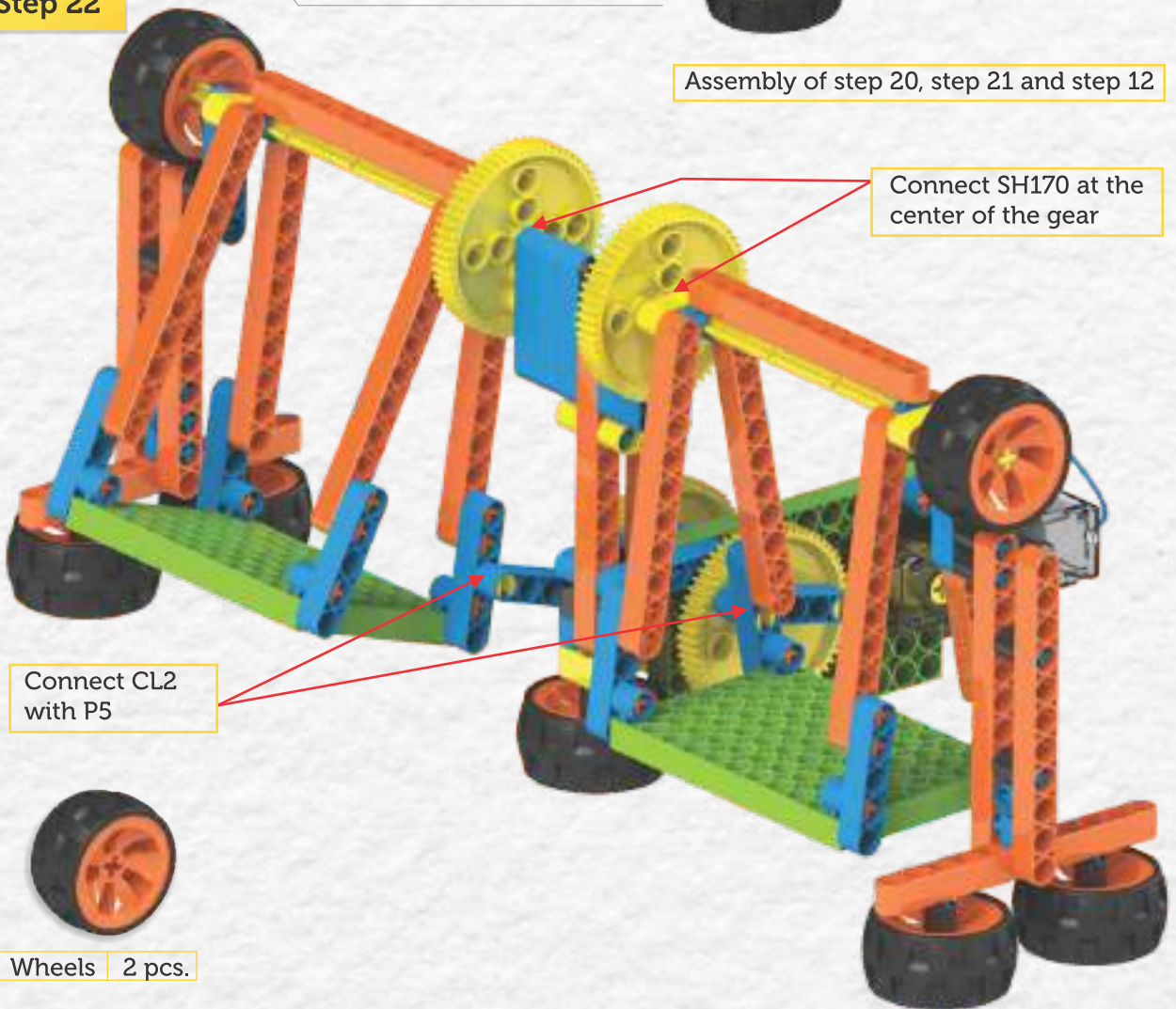

Connect CL2
with P5

Connect SH170 at the
center of the gear

Wheels 2 pcs.

Model 5

Step 1

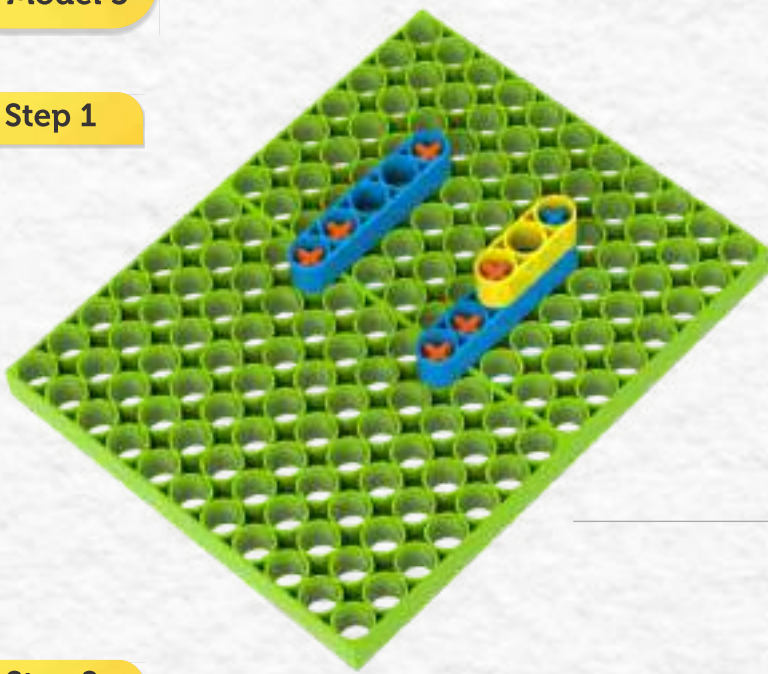

- CT2 6 pcs.
- P5 2 pcs.
- CT3 1 pc.
- P3 1 pc.
- P7X11 2 pcs.

Step 2

- CT3 3 pcs.
- P5 1 pc.
- CH2 4 pcs.
- TW1 2 pcs.

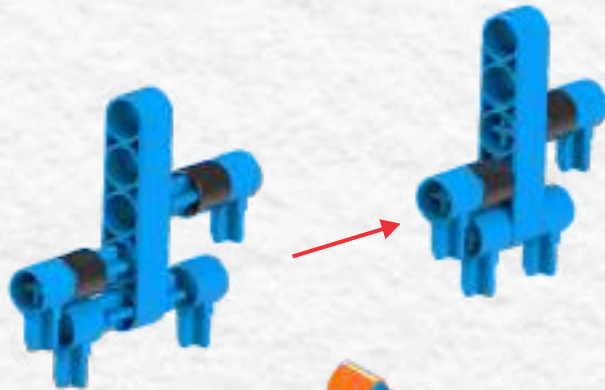

Step 3

Assembly of step 1 and 2

- CT3 4 pcs.
- P11 1 pcs.

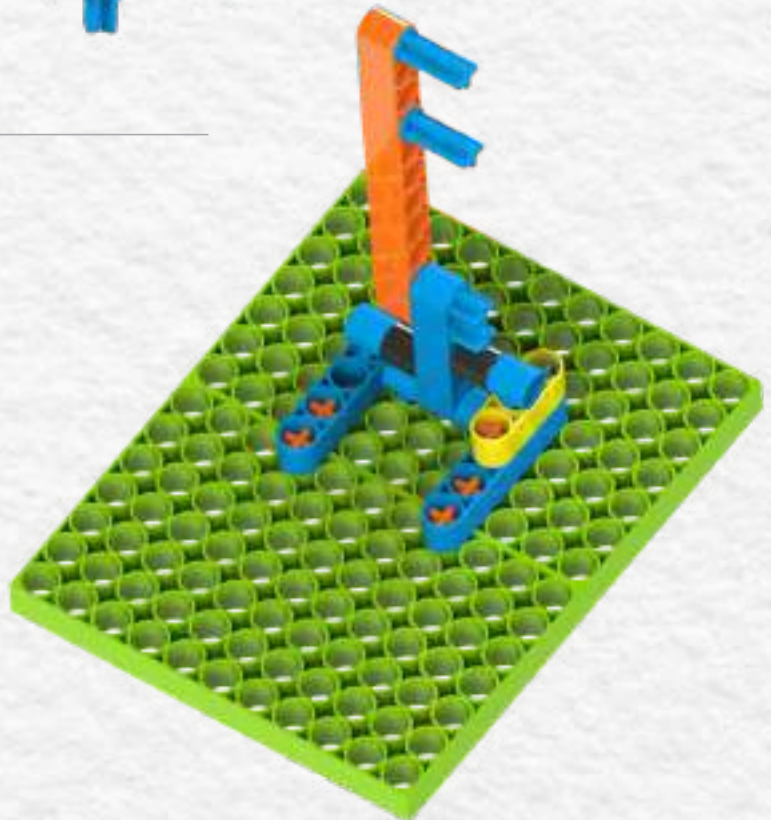

Step 4

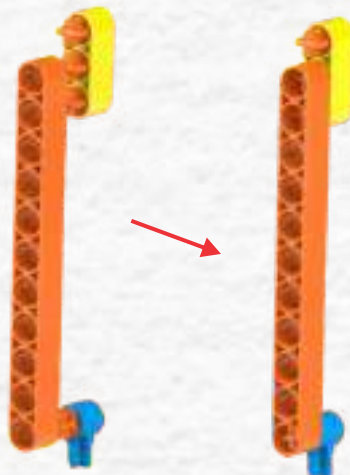
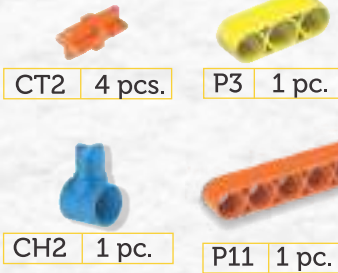

Step 5

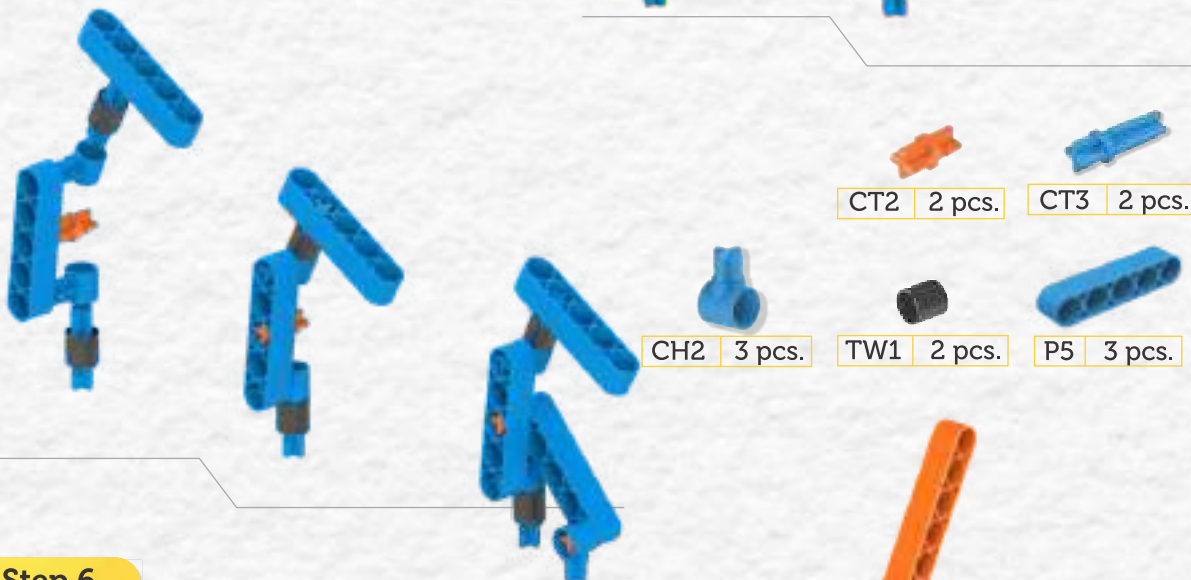

Step 6

Assembly of step 4 and 5

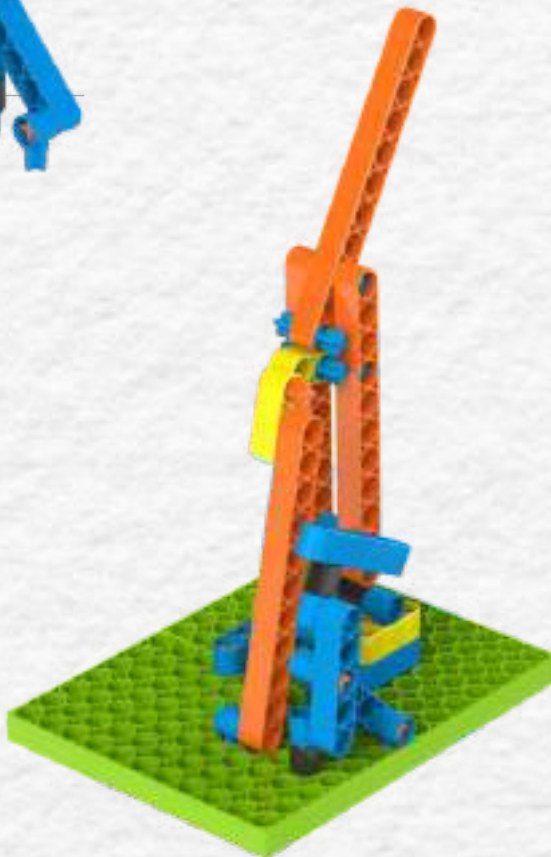
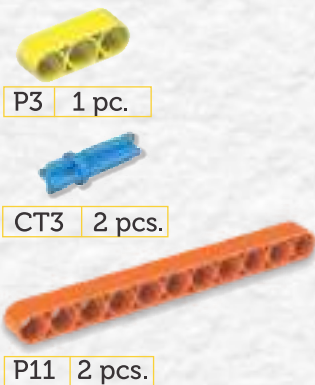

Step 7



CT2 1 pc.



CT3 3 pcs.



P3 2 pcs.



P5 1 pc.



Step 8



CT3 2 pcs.



P5 3 pcs.







Step 9

-  CH2 2 pcs.
-  P5 2 pcs.



Step 10



-  SH60 1 pc.
-  P5 1 pc.
-  CT2 2 pcs.
-  CH2 2 pcs.
-  Motor with Battery Box

Step 11

Assembly of step 9 and 10

-  P5 1 pc.



Step 14



CT2 16 pcs.



P3 2 pcs.

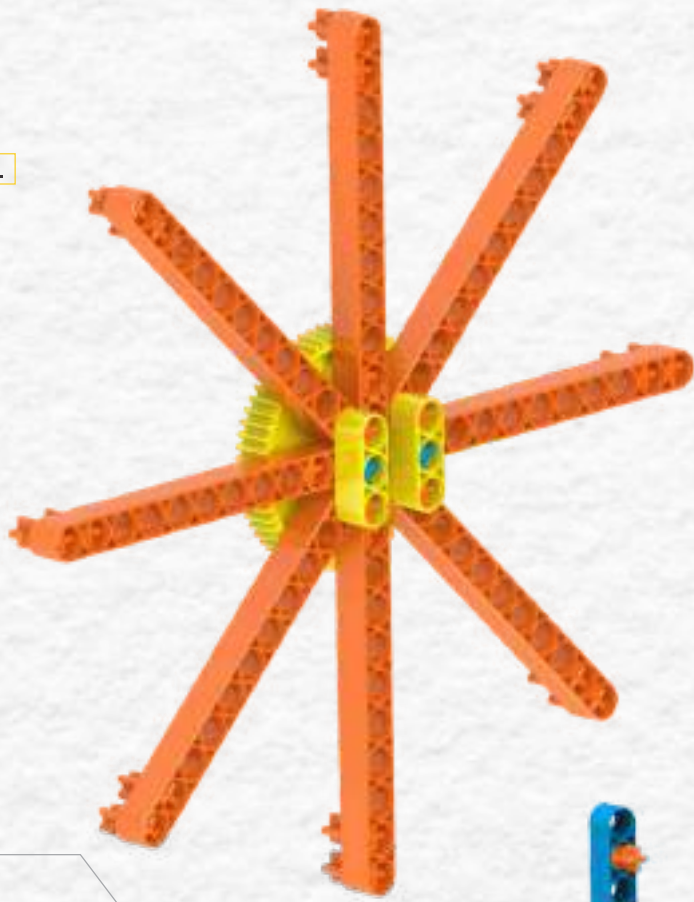

Step 15



CT2 4 pcs.



CT3 4 PCS.



P5 8 pcs.

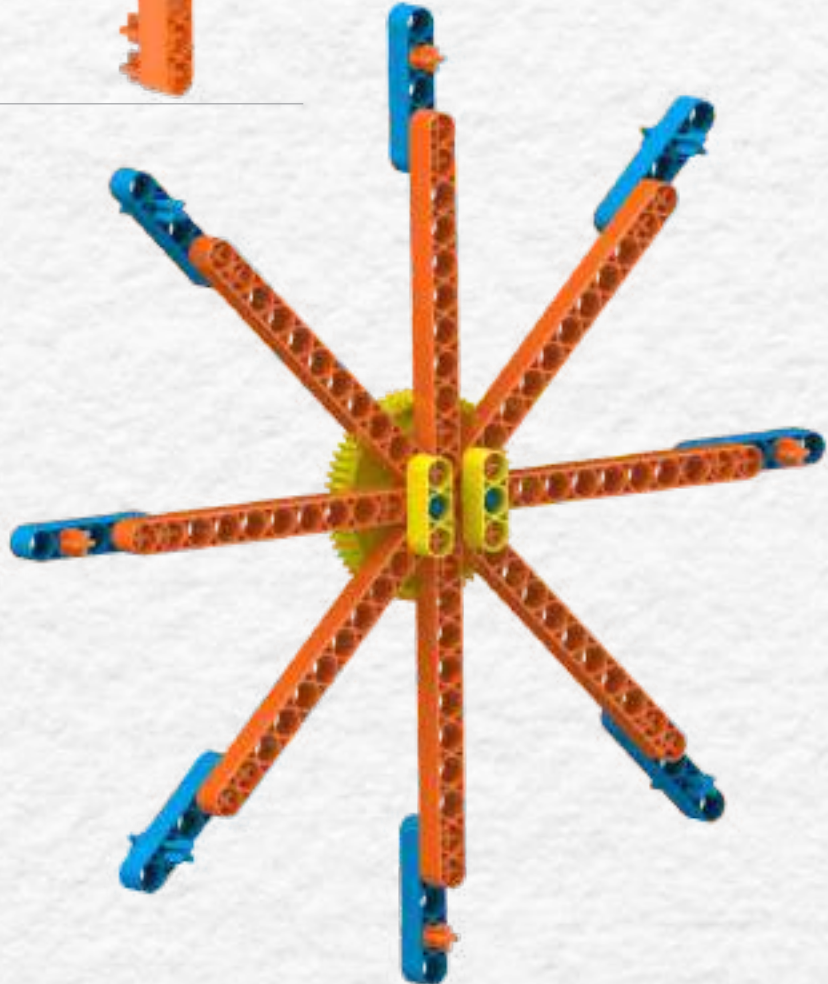

Step 16



P11 8 pcs.

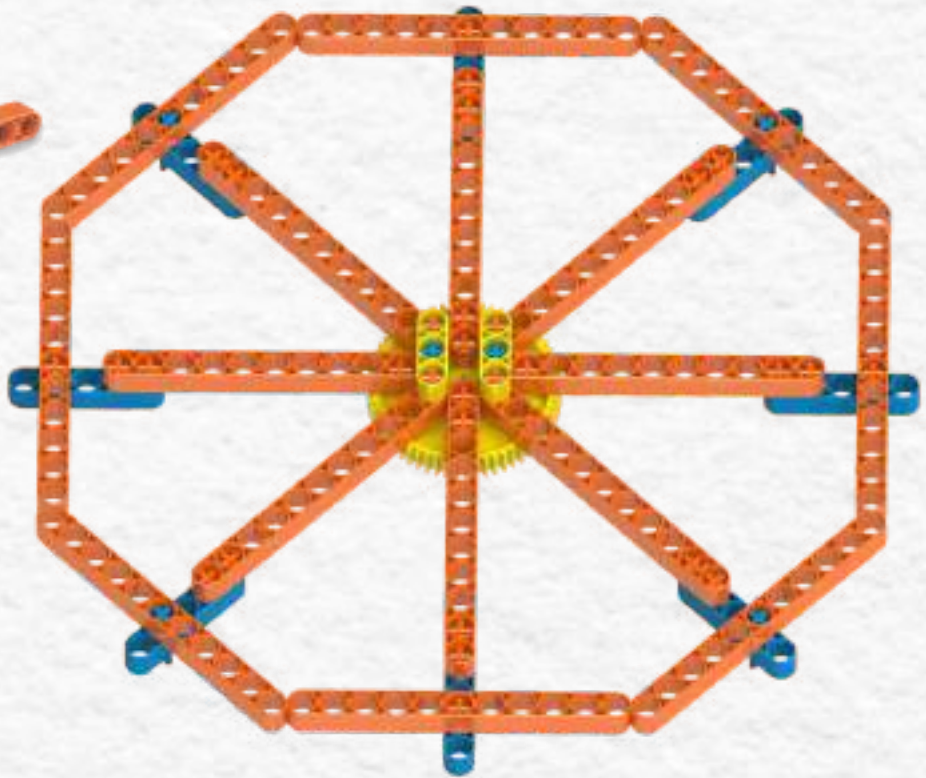

Step 17



CT3 24 pcs.



P3 8 pcs.

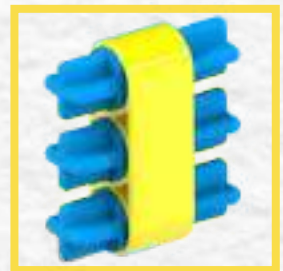
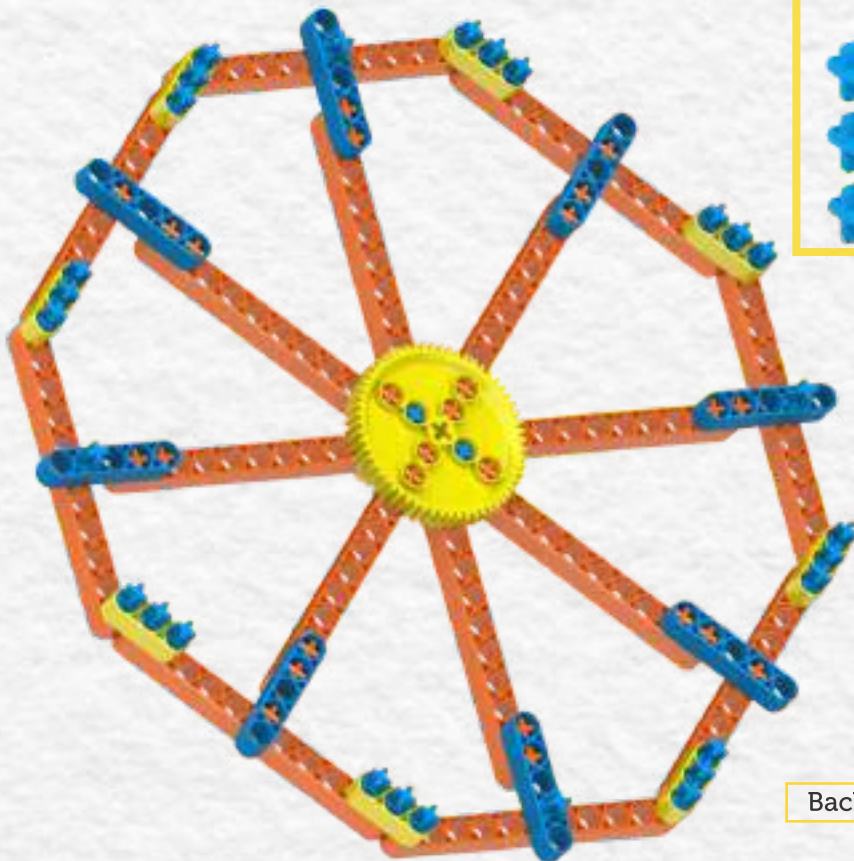

Make 8

Backside

Step 18

Blix



P11 8 pcs.



Step 19



TW1 8 pcs.



CH2 16 pcs.



CT3 8 pcs.



CL2 8 pcs.



P3 8 pcs.



Wheels 8 pcs.



Make 8

Step 20

Assembly of step 18 and 19



Step 21

Assembly of step 20 and 12

Attach step 20 on the yellow shaft

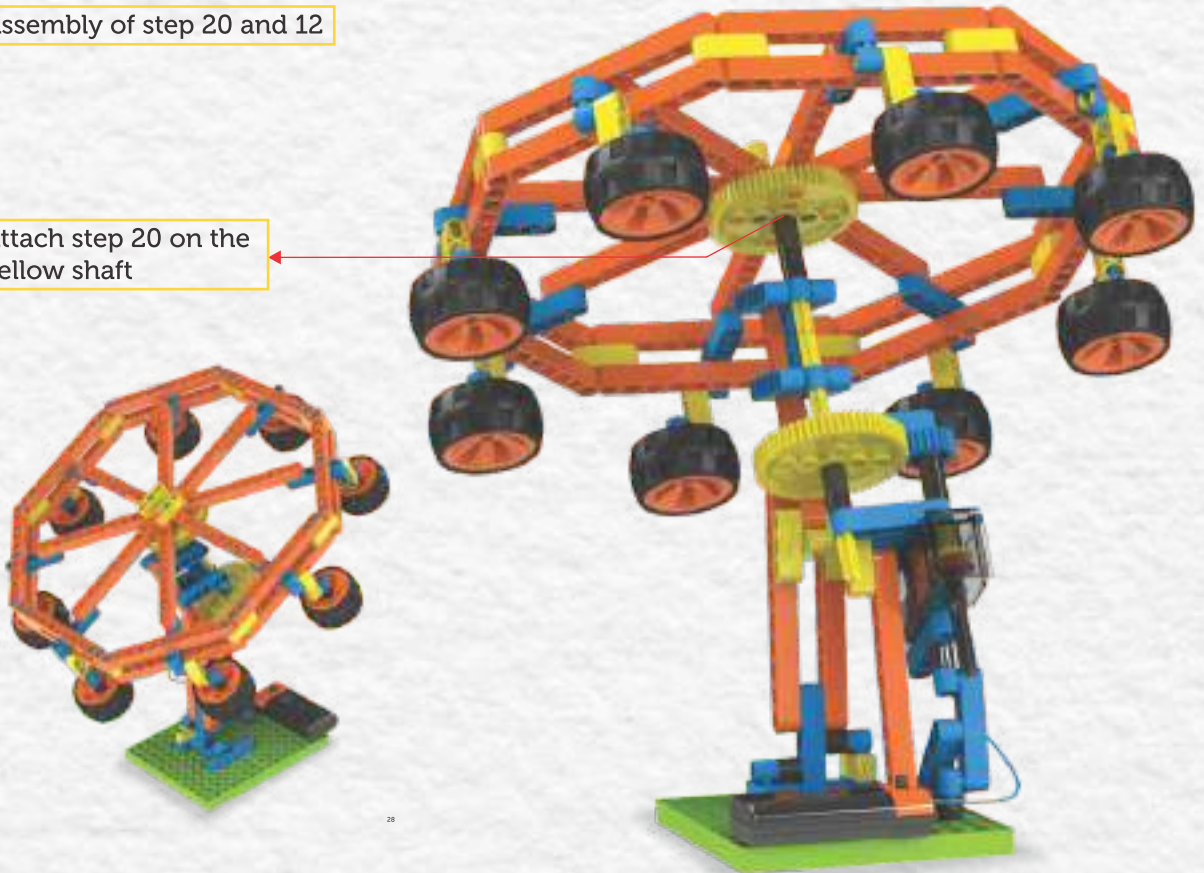

Step 1



CT2 12 pcs.



CT3 4 pcs.



P7X11 2 pcs.

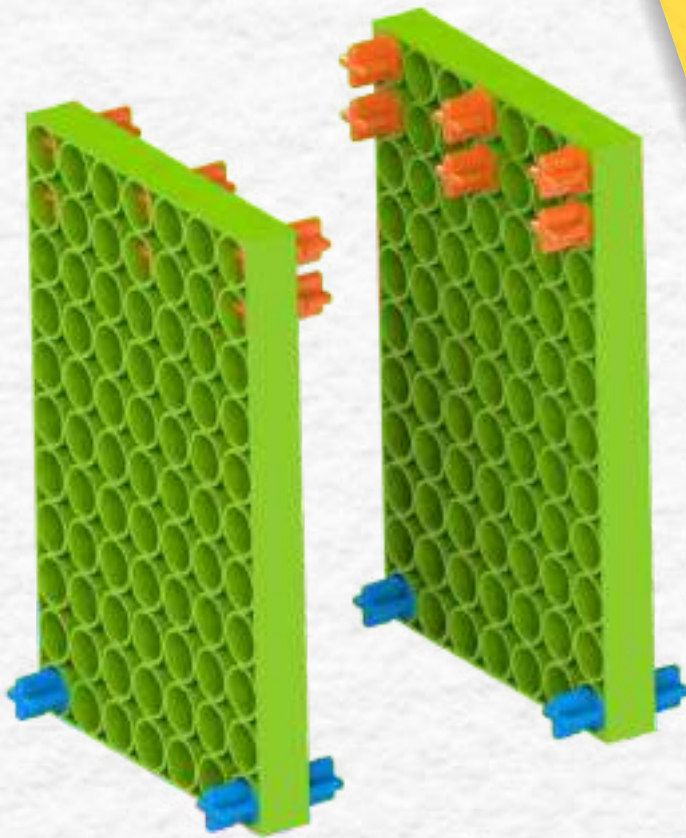

Step 2



CT2 8 pcs.



CH2 8 pcs.



P3 4 pcs.



P5 2 pcs.

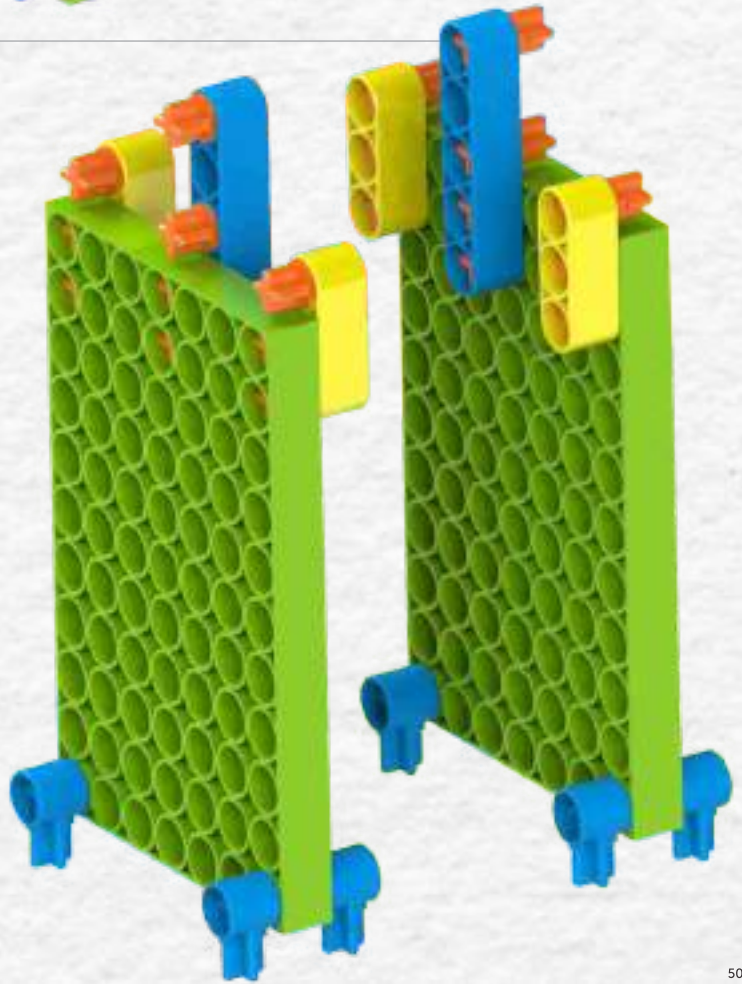
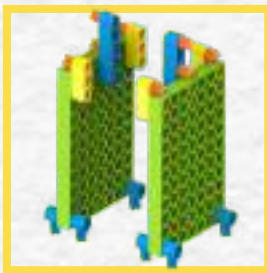

Step 3

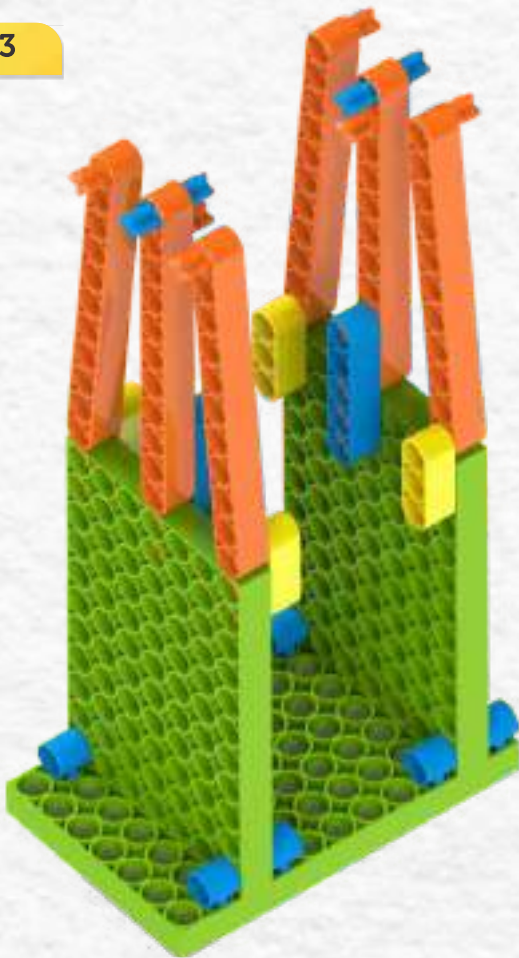

CT2 6 pcs.

CT3 2 pcs.

P7X11 1 pc.

P11 6 pcs.



Step 4

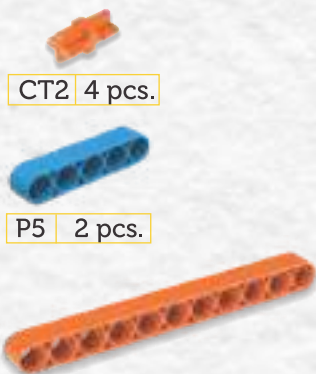

CT2 4 pcs.

P5 2 pcs.

P11 2 pcs.

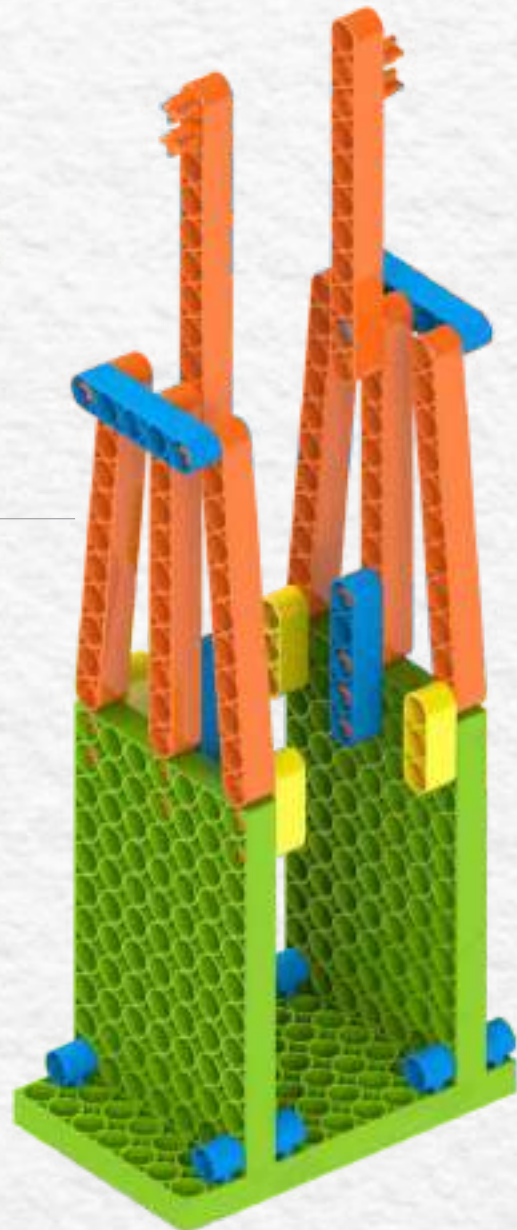

Step 5



G(60) 1 pc.

P11 1 pc.

SH170 1 pc.

Blix

Step 6

TW1 2 pcs.

CT2 2 pcs.

CT3 1 pc.

P5 1 pc.

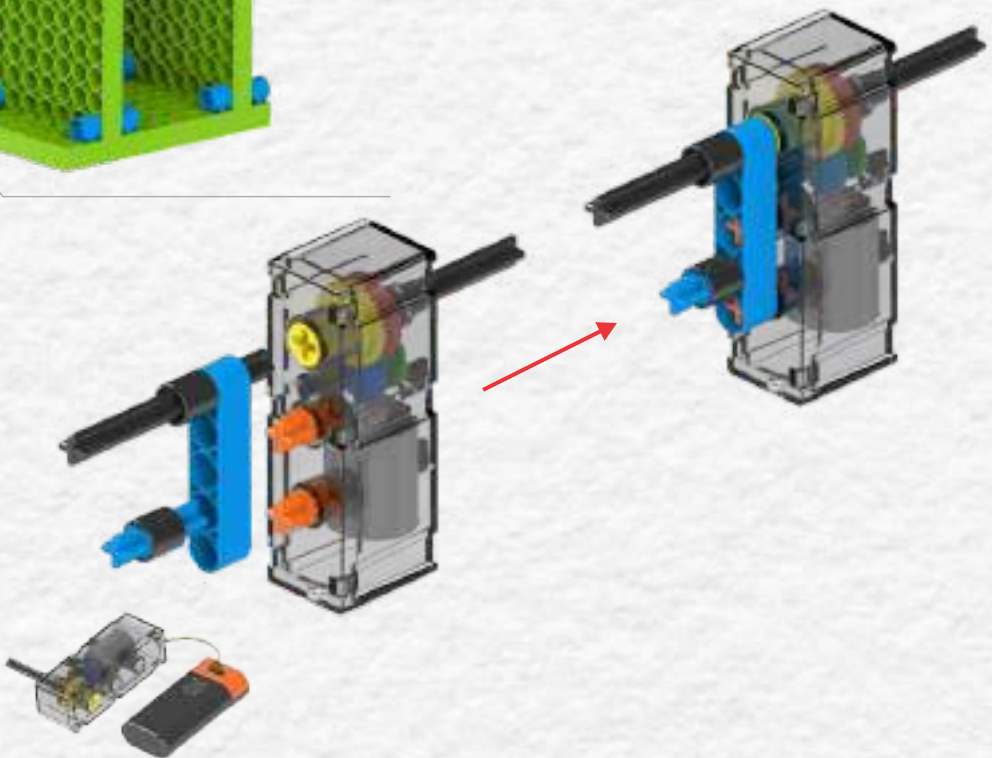

Motor with
Battery Box

Step 7

Assembly of step 6 and 5



TW1 6 pcs.



G(60) 1 pc.



SH60 4 pcs.



Step 8



TW1 1 pc.



CL2 1 pc.



CT3 1 pc.

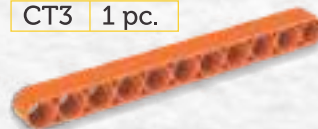

P11 1 pc.

Step 9



G(20) 2 pcs.



G(20) Idler 1 pc.



G(60) 1 pc.

Blix

Step 10

Attach final assembly here



TW1 2 pcs.



G(60) 1 pc.

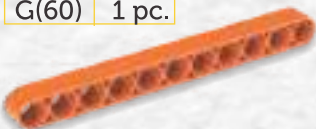

P11 1 pc.



Step 11



CT3 8 pcs.



G(60) 1 pc.

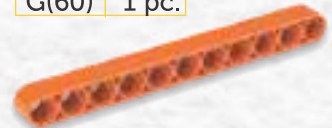

P11 4 pcs.

Step 12



CT2 12 pcs.



P3 4 pcs.

Attach with step 11

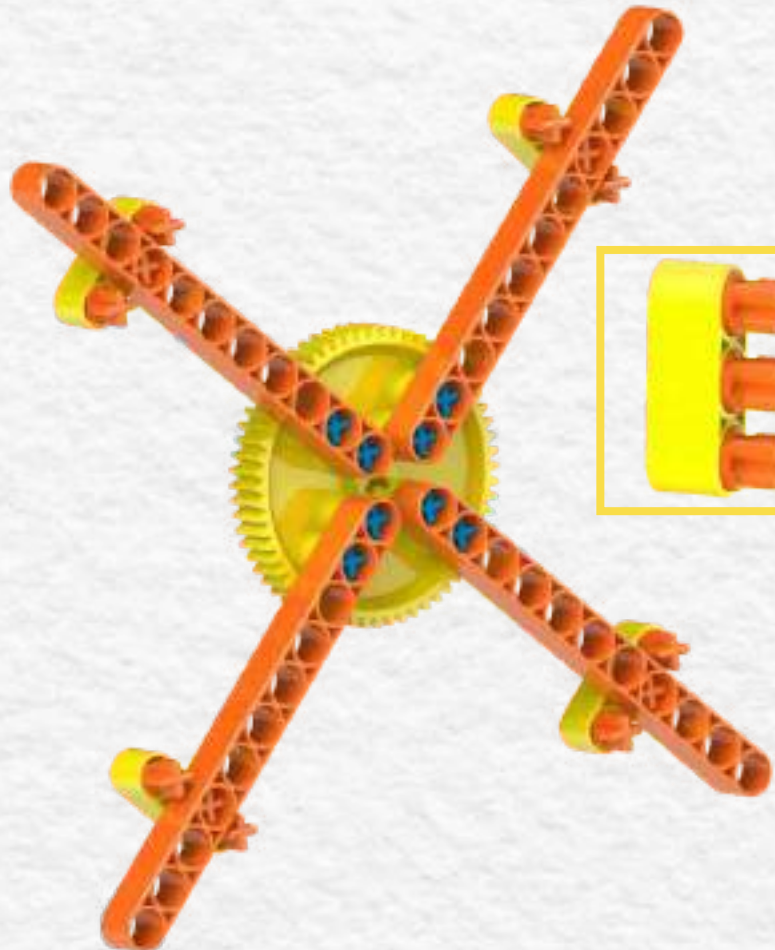

Step 14

Blix

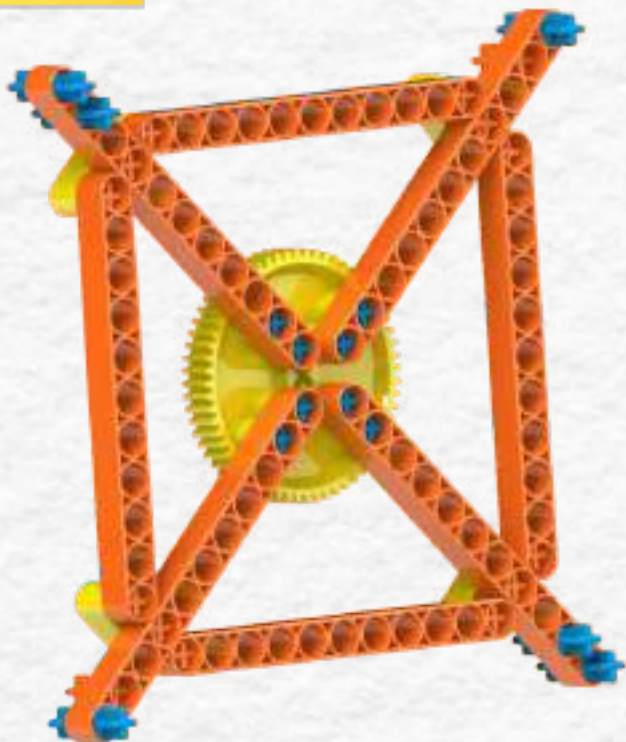

CT2 2 pcs.

CT3 6 pcs.

P11 4 pcs.

Step 15

TW1 8 pcs.

CT3 8 pcs.

P5 4 pcs.

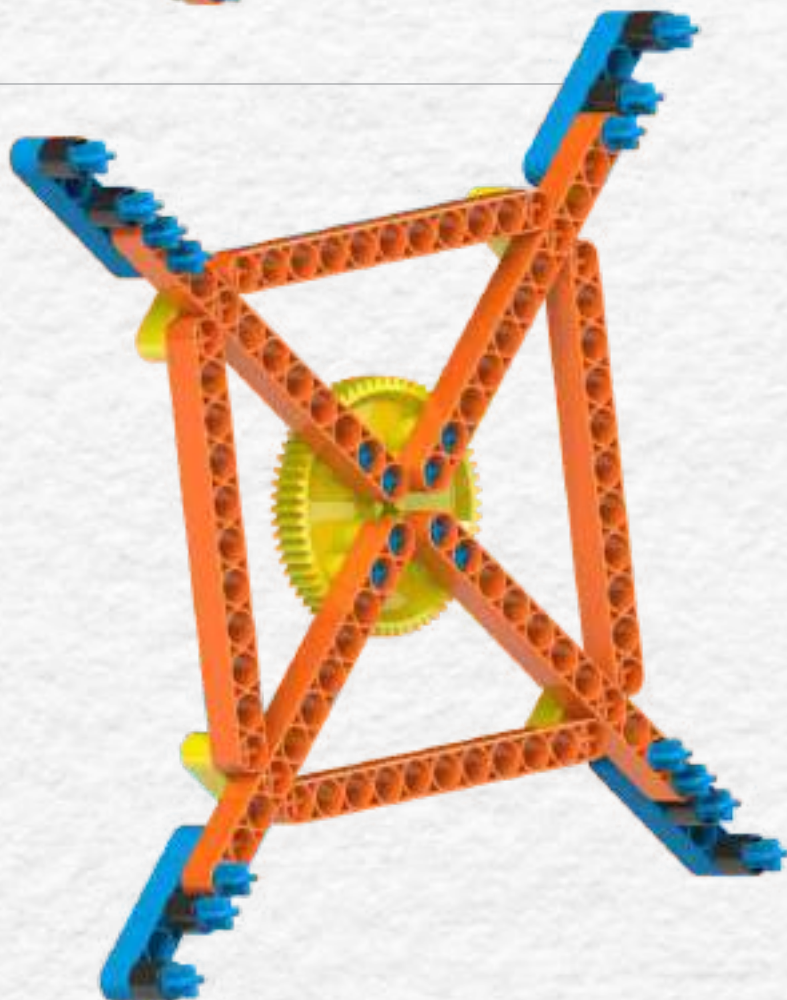

Step 16

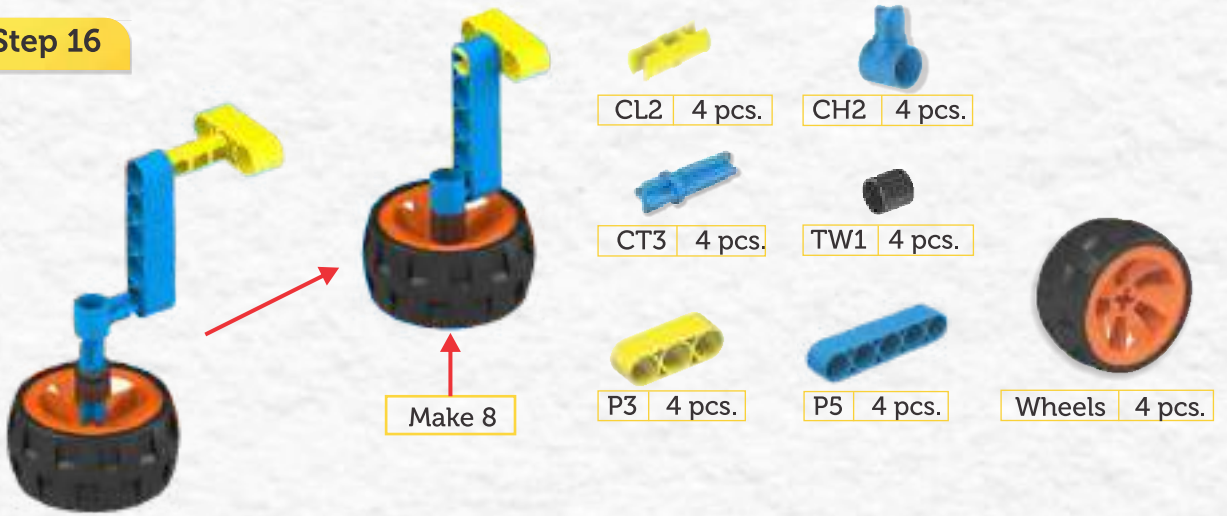

Step 17

Assembly of step 16 and 15

Make another same assembly



Step 18

Assembly of step 17 and 10

Blix



Check out our other Blix Sets



Blix CARTS - 1



Blix CARTS - 2



For detailed steps please visit www.blix.in

POWER SCREW

Blix



GEAR BOX



Also From

ZEPHYR

More Than Just Play

MECHANIX - Robotix - 3



MECHANIX - Battle Station - Transporter



MECHANIX - Eiffel Tower



MECHANIX

Blix

AMUSEMENT PARK



P3 24 pcs.

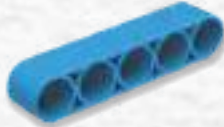

P5 25 pcs.



P11 30 pcs.



CT2 70 pcs.



CT3 65 pcs.



CL2 12 pcs.



CH2 45 pcs.



TW1 40 pcs.



P7X11 3 pcs.



G(60) 4 pcs.



G(20) 4 pcs.



G(20) Idler 4 pcs.



Wheels 8 pcs.



SH170 2 pcs.



SH60 4 pcs.

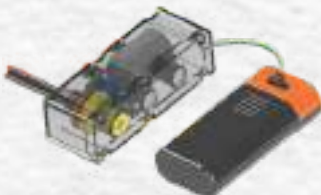

Motor With Battery
Box 1pc.



Remover Tool 1 pc.